

Product Specification

产品规格书

Customer Name:

客户名称

Customer P/N:

客户料号

Product Name:

产品名称

晶体管光耦

Product P/N:

产品型号

MT-356T(ABCD)

Sending Date:

制定日期

2026/04/15

<input type="checkbox"/> Technical Reference 技术参考		<input type="checkbox"/> Sample 样品		<input checked="" type="checkbox"/> Mass Product 量产供货	
Customer approval 客户审核			Supplier approval 供方审核		
Approved 核准	Audit 确认	Confirmation 制作	Approved 核准	Audit 确认	Confirmation 制作
<input type="checkbox"/> Qualified 接受	<input type="checkbox"/> Disqualified 不接受		Date: 日期:		



ATTENTION
OBSERVE PRECAUTIONS
FOR HANDLING
ELECTROSTATIC
SENSITIVE DEVICES

SHENZHEN MATELIGHT ELECTRONICS CO.,LTD.

Address: 5th Floor, No. 8-5 Factory, Tongfu Industrial Zone, Aiqun Road, Shangwu

Community, Shiyuan Street, Bao'an District, Shenzhen

公司地址: 深圳市宝安区石岩街道上屋社区爱群路同富裕工业区 8-5 号厂房 5 楼

Tel(电话): +86-13420946693 QQ: 3001291430 Skype/邮箱:hedy.xu@matelight.com

Photocoupler

Model No.: MT-356T(ABCD)

Features:

- Current transfer ratio (50%~600% at $I_F=5\text{mA}$; $V_{ce}=5\text{V}$)
- High input-output isolation voltage($V_{iso}= 3750\text{Vrms}$)
- SOP-4 Package
- Mini-flat package : 2.0mm profile
- ESD pass (HBM8000V/MM2000V)
- MSL class1
- Safety approval

UL 1577

VDE

- RoHS compliance

Applications:

- Hybrid substrates that require high density mounting
- Programmable controllers

Functional Diagram

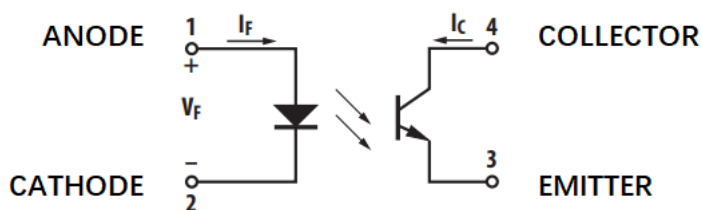

Absolute Maximum Ratings

(Ta=25°C)

	Parameter	Symbol	Rating	Unit
Input	Forward Current	I_F	50	mA
	Reverse Voltage	V_R	6	V
	Power Dissipation	P	70	mW
	Junction Temperature	T_J	125	°C
Output	Collector - Emitter Voltage	V_{CEO}	80	V
	Emitter - Collector Voltage	V_{ECO}	6	V
	Collector Current	I_c	50	mA
	Collector Power Dissipation	P_c	150	mW
	Total Power Dissipation	P_{tot}	170	mW
*1	Isolation Voltage	V_{iso}	3750	V_{rms}
	Operating Temperature	T_{opr}	-55~+110	°C
	Storage Temperature	T_{stg}	-55~+150	°C
*2	Soldering Temperature	T_{sol}	260	°C

*1: AC For 1 Minute, R.H. = 40 ~ 60%

Isolation voltage shall be measured using the following method

- (1) Short between anode and cathode on the primary side and between collector and emitter on the secondary side
- (2) The isolation voltage tester with zero-cross circuit shall be used
- (3) The waveform of applied voltage shall be a sine wave

*2: For 10 Seconds

Electrical / Optical Characteristics (Ta=25°C)

	Parameter	Symbol	Condition	Min.	Typ.	Max.	Unit
Input	Forward Voltage	V _F	I _F =20mA	-	1.2	1.4	V
	Reverse Current	I _R	V _R =4V	-	-	10	uA
	Terminal Capacitance	C _t	V=0, f=1KHz	-	30	250	pF
Output	Collector Dark Current	I _{CEO}	V _{CE} =20V, I _F =0			100	nA
	Collector-Emitter Breakdown Voltage	BV _{CEO}	I _C =0.1mA, I _F =0	80	-	-	V
	Emitter-Collector Breakdown Voltage	BV _{ECO}	I _E =10μA, I _F =0	6	-	-	V
TRANSFER CHARACTERISTICS	Collector Current	I _C	I _F =5mA, V _{CE} =5V	2.5	-	30	mA
	*Current Transfer Ratio	CTR	I _F =5mA, V _{CE} =5V	50	-	600	%
	Collector-Emitter Saturation Voltage	V _{CE(SAT)}	I _F =20mA, I _C =1mA	-	-	0.2	V
	Isolation Resistance	R _{iso}	DC500V, 40 ~ 60% R.H.	5×10 ¹⁰	1×10 ¹¹	-	Ω
	Floating Capacitance	C _f	V=0, f=1MHz	-	0.6	1	pF
	Response Time (Rise)	tr	V _{CE} =2V, I _C =2mA R _L =100Ω	-	4	18	us
	Response Time (Fall)	tf		-	3	18	us

$$* CTR = \frac{I_C}{I_F} \times 100\%$$

CTR Rank	Min	Max	Condition
A	80	160	I _F =5mA; V _{ce} =5V
B	130	260	I _F =5mA; V _{ce} =5V
C	200	400	I _F =5mA; V _{ce} =5V
D	300	600	I _F =5mA; V _{ce} =5V
None Or Other	50	600	I _F =5mA; V _{ce} =5V

CHARACTERISTICS CURVES

Fig.1 Forward Current vs. Ambient Temperature

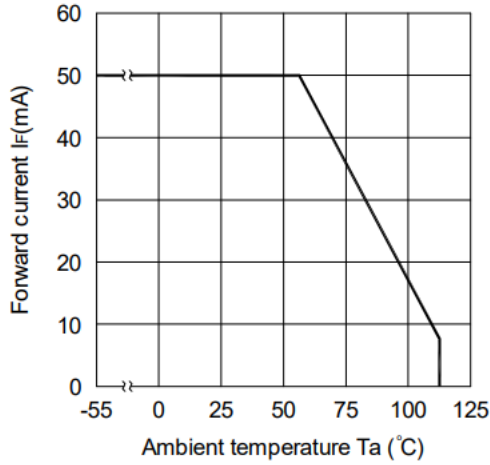

Fig.2 Collector Power Dissipation vs. Ambient Temperature

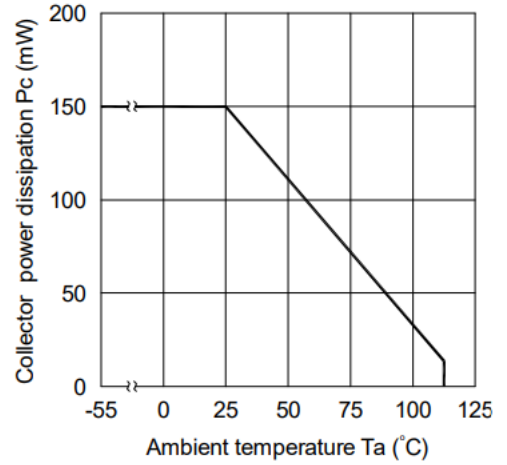

Fig.3 Collector-emitter Saturation Voltage vs. Forward Current

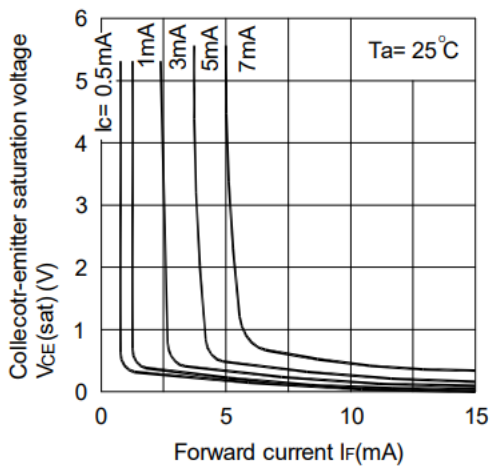

Fig.4 Forward Current vs. Forward Voltage

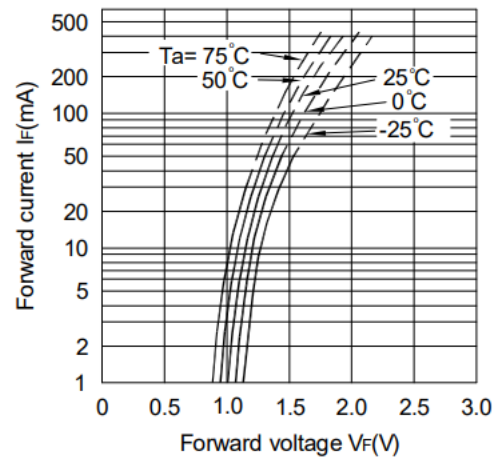

Fig.5 Current Transfer Ratio vs. Forward Current

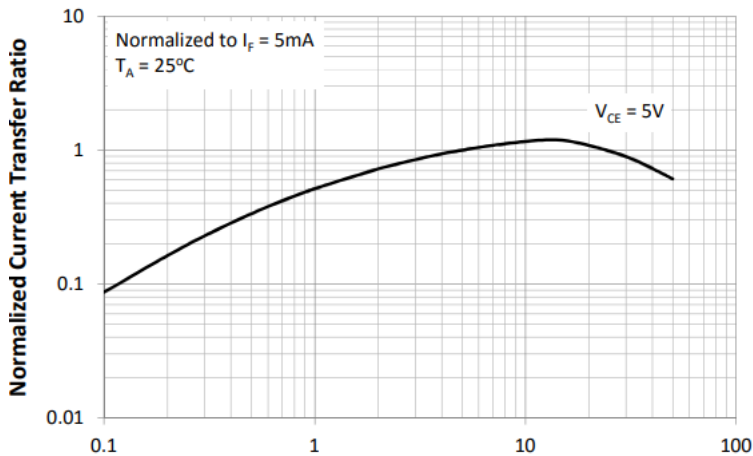

Fig.6 Collector Current vs. Collector-emitter Voltage

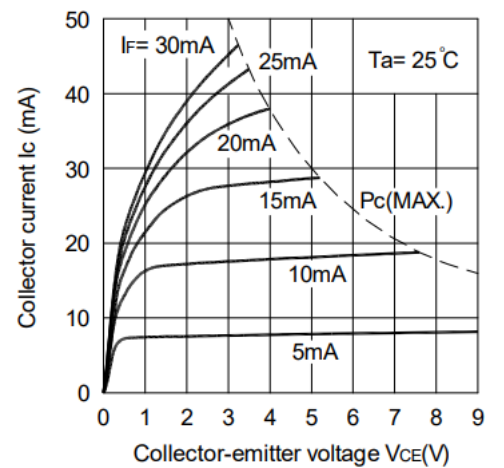

Fig.7 Relative Current Transfer Ratio vs. Ambient Temperature

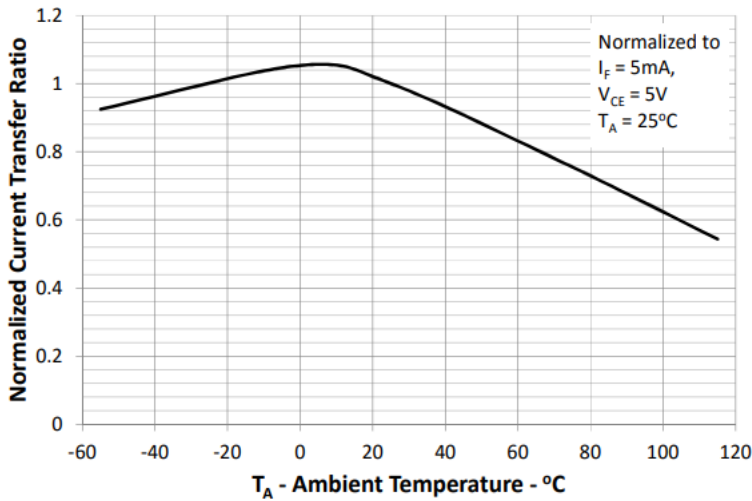

Fig.8 Collector-emitter Saturation Voltage vs. Ambient Temperature

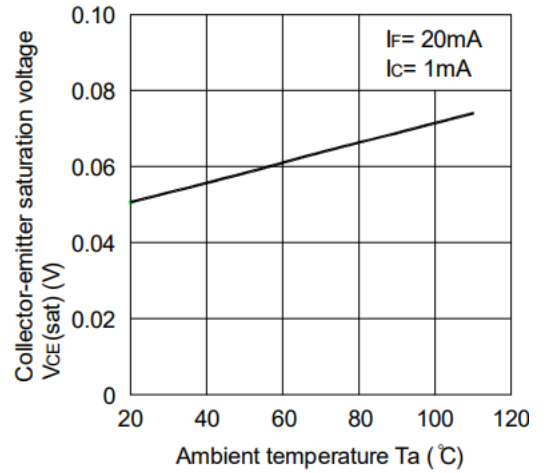

Fig.9 Collector Dark Current vs. Ambient Temperature

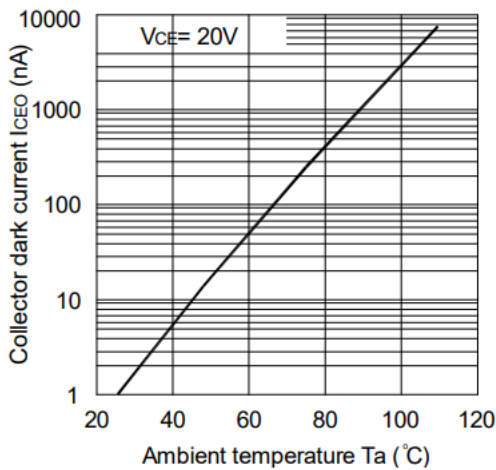

Fig.10 Response Time vs. Load Resistance

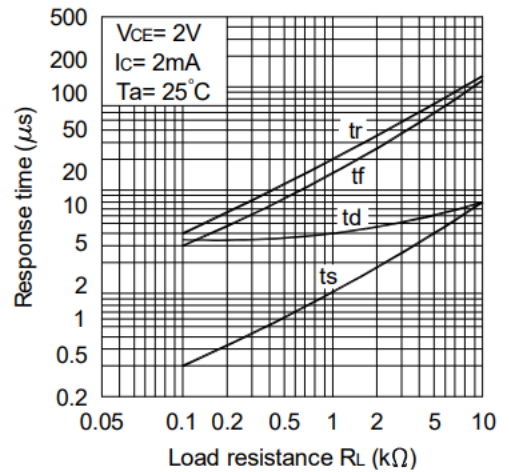
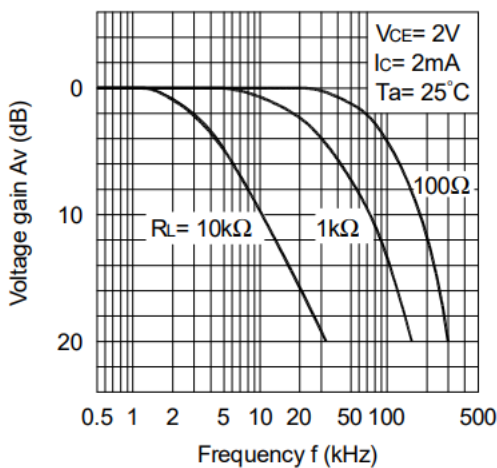
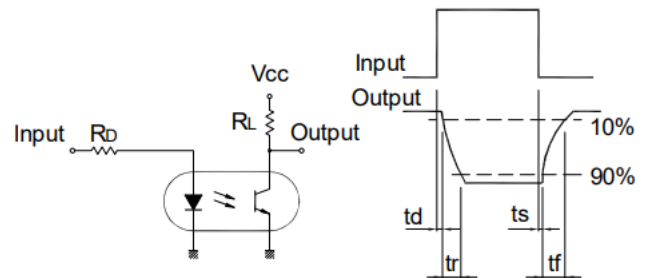

Fig.11 Frequency Response



Test Circuit for Response Time



Test Circuit for Frequency Response

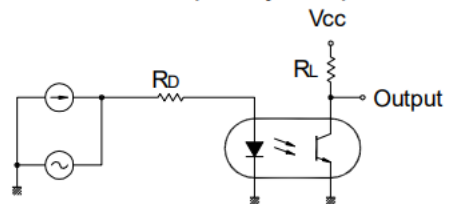

Naming Rule

MT-356-X-Y-WW-V-G

- MT---Logo
- 356---Part Number
- (X)---Representative: ABCD
- (Y)---Product Year
- (WW)---product lifecycle
- (V)---VDE
- (G)---Package Width(None=3.85mm Or 36=3.6mm")

Example:MT-356-X-Y-WW-V-G

Marking

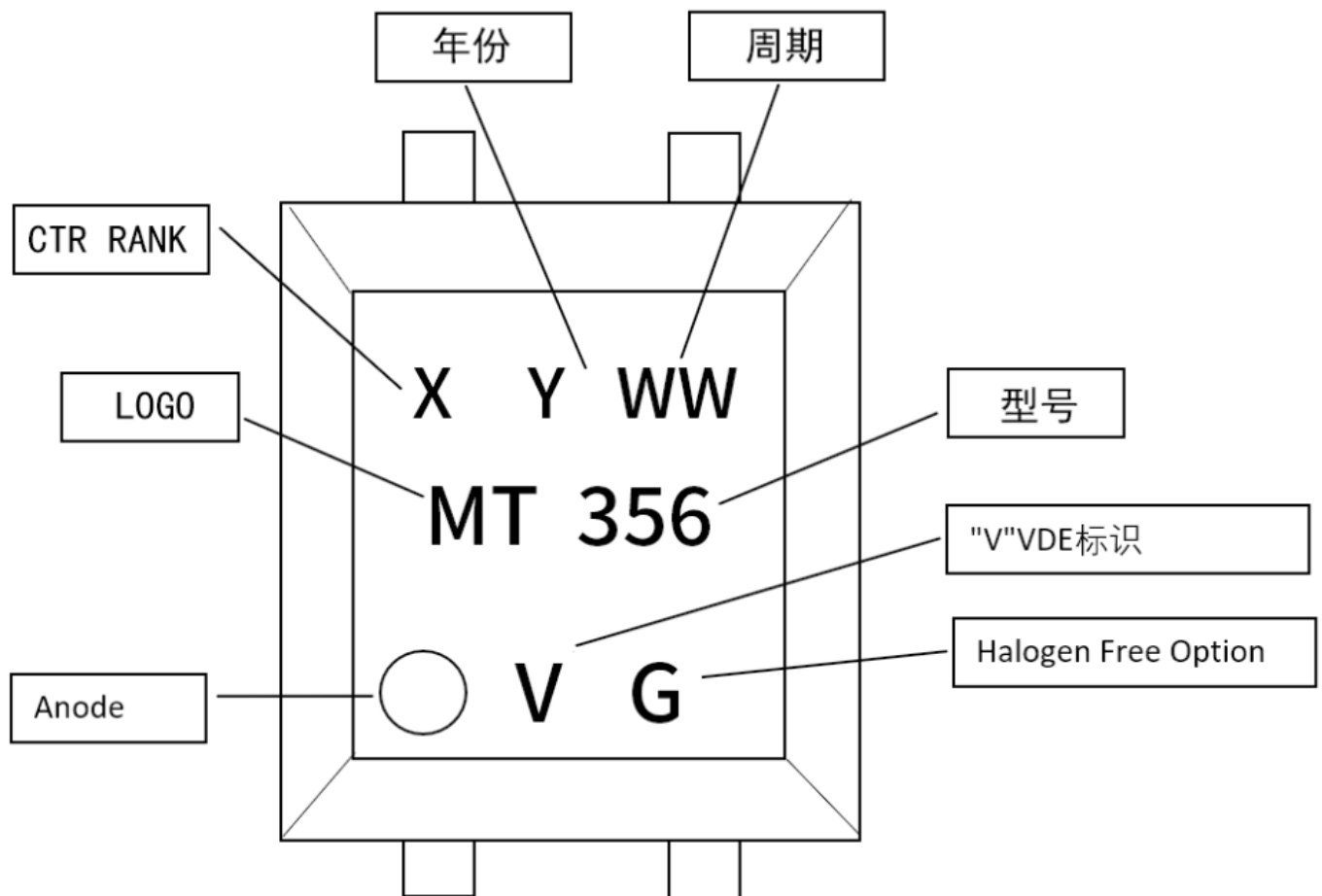

Package Dimensions

➤ **Package Width=3.85mm**

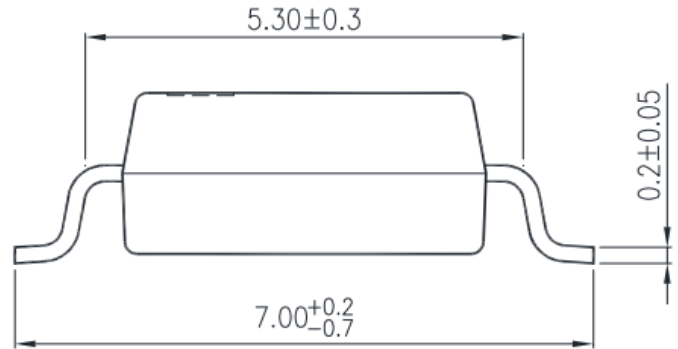
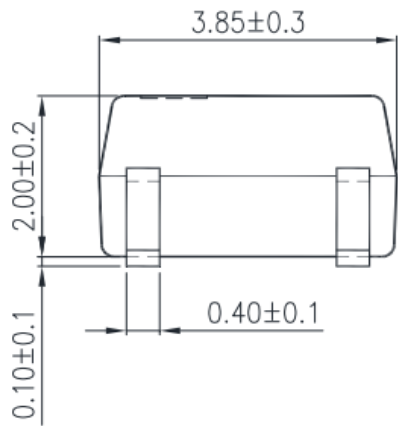

➤ **Package Width=3.6mm**

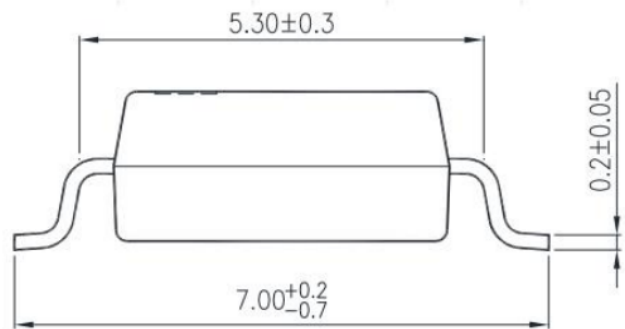
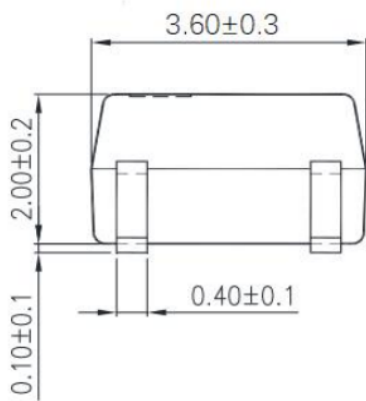

Surface mount (Footprint Dimensions)

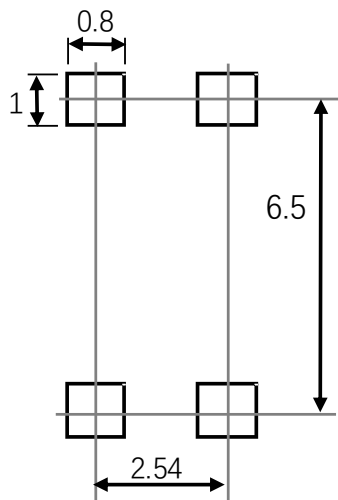

Carrier Tape Specifications

➤ “TP1” Tape(3000 units per reel)

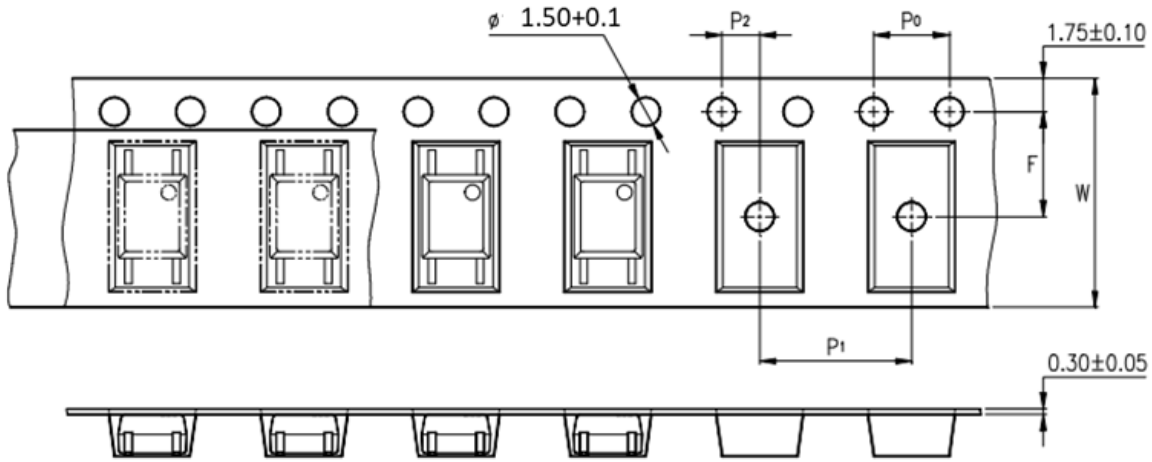

➤ “TP” Tape(3000 units per reel)

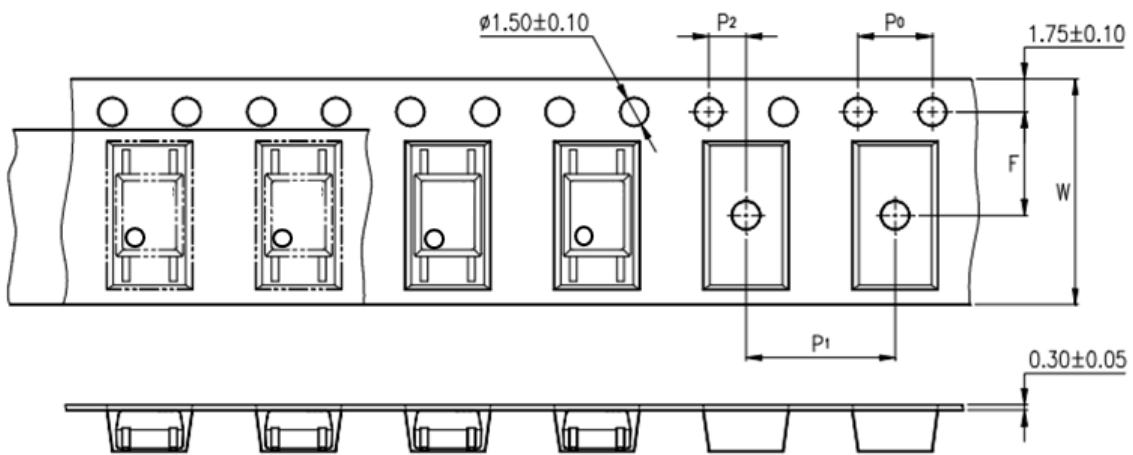

Symbol	Description	Dimensions in mm (inches)
W	Tape wide	12±0.3 (0.472)
P_0	Pitch of sprocket holes	4±0.1 (0.157)
F	Distance of compartment	5.5±0.1 (0.217)
P_2		2±0.1 (0.079)
P_1	Distance of compartment to compartment	8±0.1 (0.315)

Solder Reflow Temperature Profile (JEDEC-STD-020C compliant)

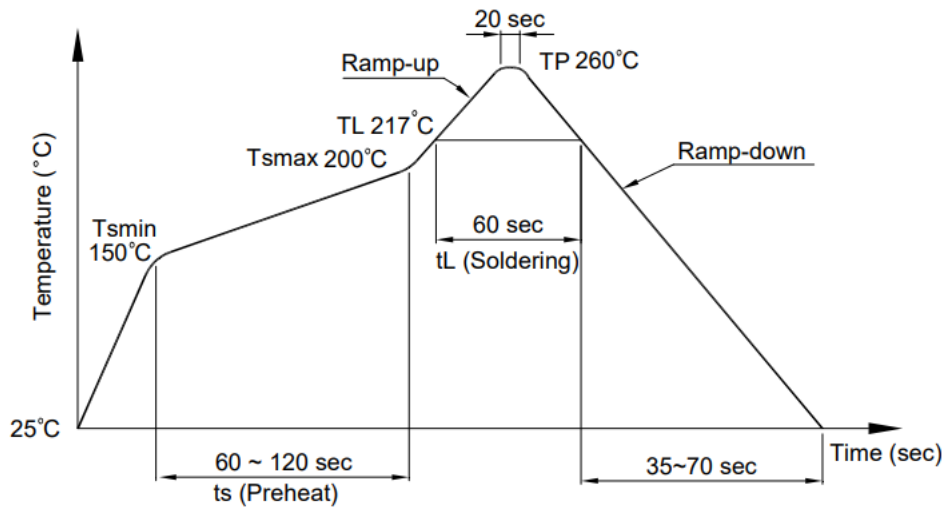

Profile Item	Conditions
Preheat	
- Temperature Min (T_{Smin})	150°C
- Temperature Max (T_{Smax})	200°C
- Time (min to max) (t_s)	90±30 sec
Soldering zone	
- Temperature (T_L)	217°C
- Time (t_L)	60 ~ 100 sec
Peak Temperature (T_P)	260°C
Ramp-up rate	3°C / sec max
Ramp down rate	3~6°C / sec

One time soldering reflow is recommended within the condition of temperature and time profile shown
Do not solder more than three times

Wave Soldering (JEDEC22A111 compliant)

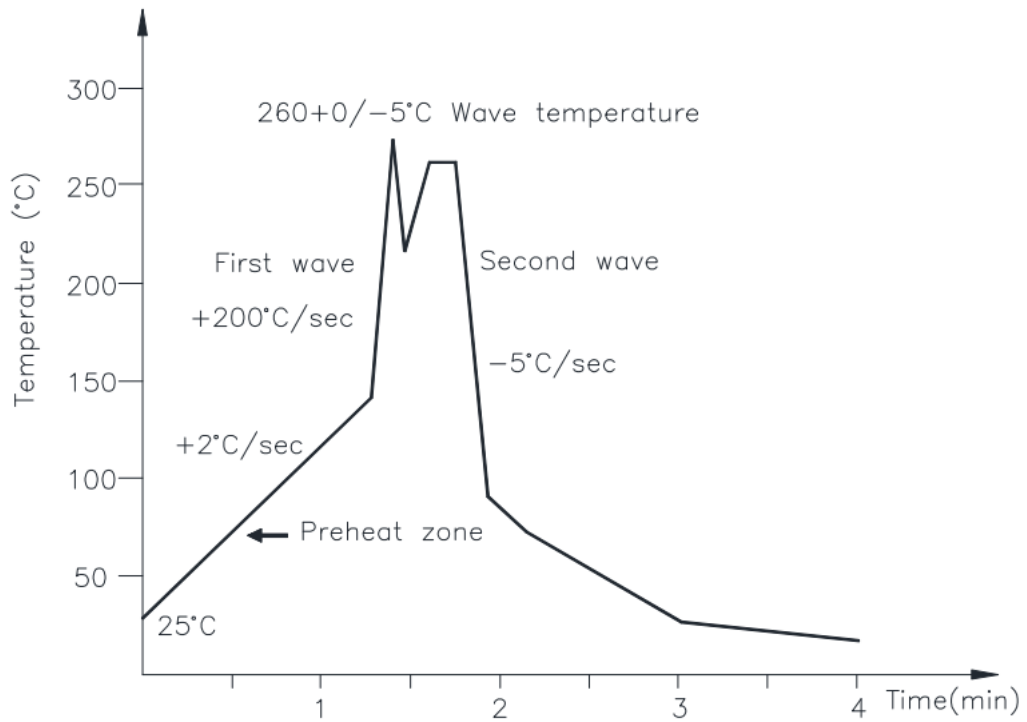

One time soldering is recommended within the condition of temperature

Temperature: 260+0/-5°C

Time: 10 sec

Preheat temperature: 25 to 140°C

Preheat time: 30 to 80 sec