



PRODUCT DATA SHEET



To learn more about JGSEMI, please visit our website at



Datasheet



Resources



Samples

Please note: Please check the JINGAO Semiconductor website to verify the updated device numbers. The most current and up-to-date ordering information can be found at www.jg-semi.cn. Please email any questions regarding the system integration to JINGAO_questions@jgsemi.com.

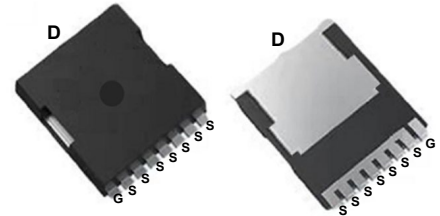
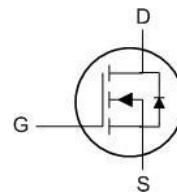
BVDSS	RDSON	ID
40V	0.75mΩ	320A

Features

- Split Gate Trench MOSFET technology
- Excellent package for heat dissipation
- High density cell design for low $R_{DS(ON)}$

Applications

- DC-DC Converters
- Power management functions
- Synchronous-rectification applications


TOLL-8L


Absolute Maximum Ratings

Symbol	Parameter	Rating	Units
V_{DS}	Drain-Source Voltage	40	V
V_{GS}	Gate-Source Voltage	± 20	V
$I_D@T_C=25^\circ\text{C}$	Continuous Drain Current, $V_{GS} @ 10V^{1,6}$	320	A
$I_D@T_C=100^\circ\text{C}$	Continuous Drain Current, $V_{GS} @ 10V^{1,6}$	160	A
I_{DM}	Pulsed Drain Current ²	720	A
EAS	Single Pulse Avalanche Energy ³	960	mJ
I_{AS}	Avalanche Current	---	A
$P_D@T_C=25^\circ\text{C}$	Total Power Dissipation ⁴	114	W
T_{STG}	Storage Temperature Range	-55 to 150	$^\circ\text{C}$
T_J	Operating Junction Temperature Range	-55 to 150	$^\circ\text{C}$

Thermal Data

Symbol	Parameter	Typ.	Max.	Unit
$R_{\theta JA}$	Thermal Resistance Junction-Ambient ¹	---	55	$^\circ\text{C/W}$
$R_{\theta JC}$	Thermal Resistance Junction-Case ¹	---	1.1	$^\circ\text{C/W}$

Electrical Characteristics (T_J=25 °C, unless otherwise noted)

Symbol	Parameter	Conditions	Min.	Typ.	Max.	Unit
BV _{DSS}	Drain-Source Breakdown Voltage	V _{GS} =0V, I _D =250uA	40	---	---	V
ΔBV _{DSS} /ΔT _J	BV _{DSS} Temperature Coefficient	Reference to 25°C, I _D =1mA	---	---	---	V/°C
R _{DS(ON)}	Static Drain-Source On-Resistance ²	V _{GS} =10V, I _D =5mA	---	0.75	1.1	mΩ
		V _{GS} =4.5V, I _D =5mA	---	1.4	2.0	mΩ
V _{GS(th)}	Gate Threshold Voltage	V _{GS} =V _{DS} , I _D =250uA	1.3	1.7	2.3	V
ΔV _{GS(th)}	V _{GS(th)} Temperature Coefficient		---	---	---	mV/°C
I _{DSS}	Drain-Source Leakage Current	V _{DS} =4V, V _{GS} =0V, T _J =25°C	---	---	1	uA
		V _{DS} =40V, V _{GS} =0V, T _J =100°C	---	---	100	
I _{GSS}	Gate-Source Leakage Current	V _{GS} =±20V, V _{DS} =0V	---	---	±100	nA
g _{fs}	Forward Transconductance	V _{DS} =10V, I _D =50A	---	---	---	S
R _g	Gate Resistance	V _{DS} =0V, V _{GS} =0V, f=1MHz	---	3.5	---	Ω
Q _g	Total Gate Charge	V _{DS} =2V, V _{GS} =5V, I _D =50A	---	87	---	nC
Q _{gs}	Gate-Source Charge		---	F8	---	
Q _{gd}	Gate-Drain Charge		---	15	---	
T _{d(on)}	Turn-On Delay Time	V _{GS} =10V, V _{DD} =2V, R _G =3Ω, I _D =50A	---	F4	---	ns
T _r	Rise Time		---	F5	---	
T _{d(off)}	Turn-Off Delay Time		---	84	---	
T _f	Fall Time		---	44	---	
C _{iss}	Input Capacitance	V _{DS} =2V, V _{GS} =0V, f=1MHz	---	5500	---	pF
C _{oss}	Output Capacitance		---	1850	---	
C _{rss}	Reverse Transfer Capacitance		---	65	---	

Diode Characteristics

Symbol	Parameter	Conditions	Min.	Typ.	Max.	Unit
I _S	Continuous Source Current ^{1,4}	V _G =V _D =0V, Force Current	---	---	320	A
I _{SM}	Pulsed Source Current ^{2,4}		---	---	720	A
V _{SD}	Diode Forward Voltage ²	V _{GS} =0V, I _S =-1A, T _J =25°C	---	---	1.2	V
t _{rr}	Reverse Recovery Time	I _F =50A, di/dt=100A/μs, T _J =25°C	---	55	---	nS
Q _{rr}	Reverse Recovery Charge		---	53	---	nC

Note :

F¹ The data is tested by surface mounted on a 1 inch² FR-4 board with 20Z copper.

G² The data is tested by pulsed pulse width ≤ 300us duty cycle ≤ 2%

H³ The EAS data shows Max. rating at the test condition as R_{MG} > 0, V_{DD}=25V, V_{GS}=10V, L=0.5mH,

I⁴ The power dissipation is limited by 150°C junction temperature

J⁵ The data is theoretically the same as I_D and I_{DM}. In real applications it should be limited by total power dissipation.

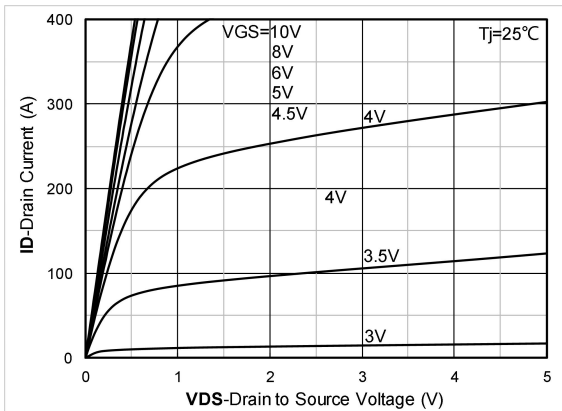
Typical Electrical and Thermal Characteristics Diagrams


Figure 1. Output Characteristics

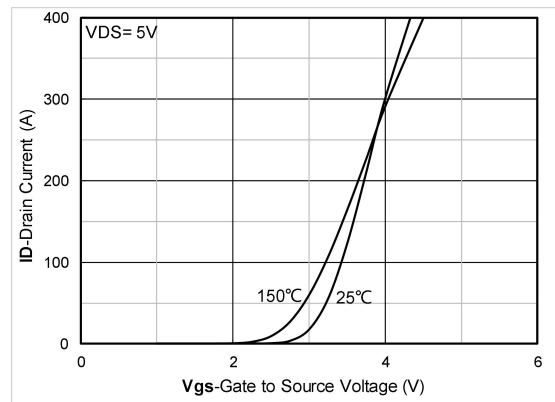


Figure 2. Transfer Characteristics

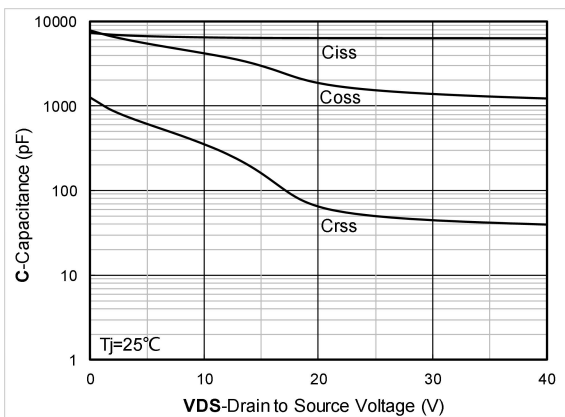


Figure 3. Capacitance Characteristics

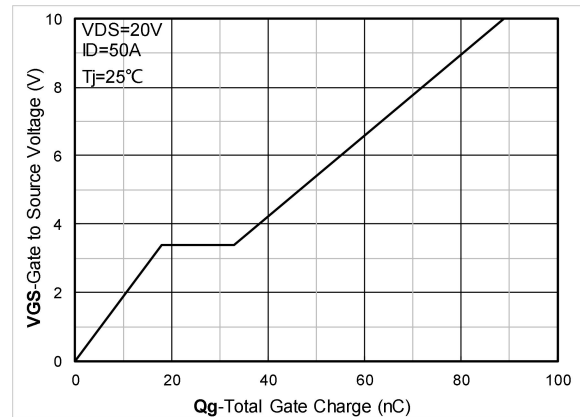


Figure 4. Gate Charge

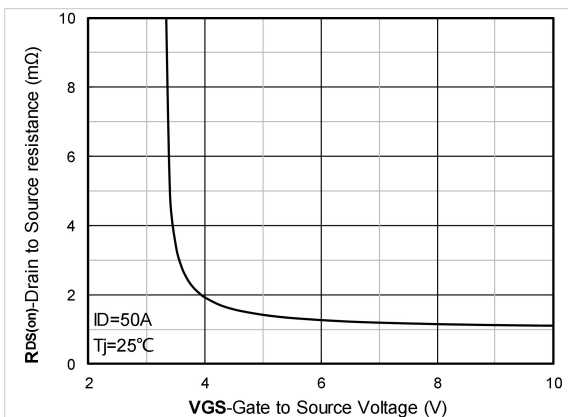


Figure 5. On-Resistance vs Gate to Source Voltage

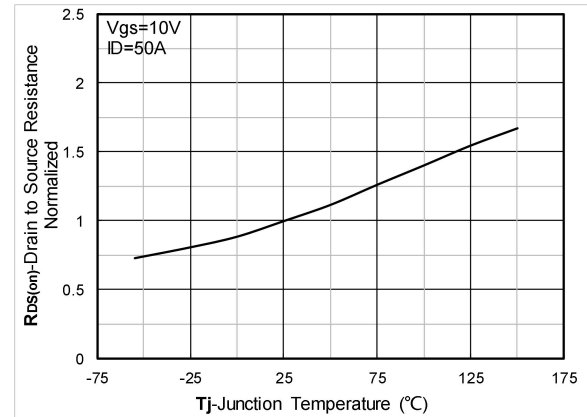


Figure 6. Normalized On-Resistance

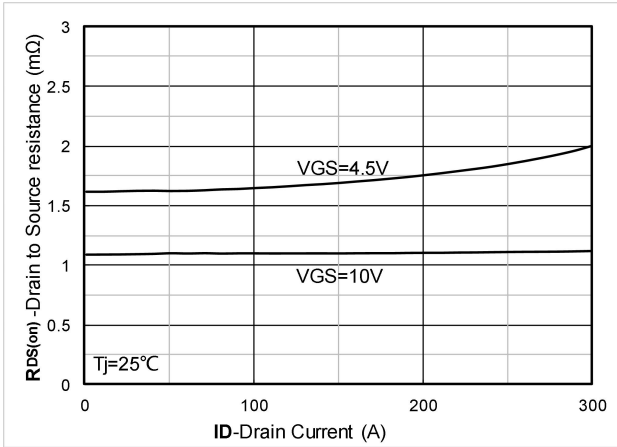


Figure 7. RDS(on) VS Drain Current

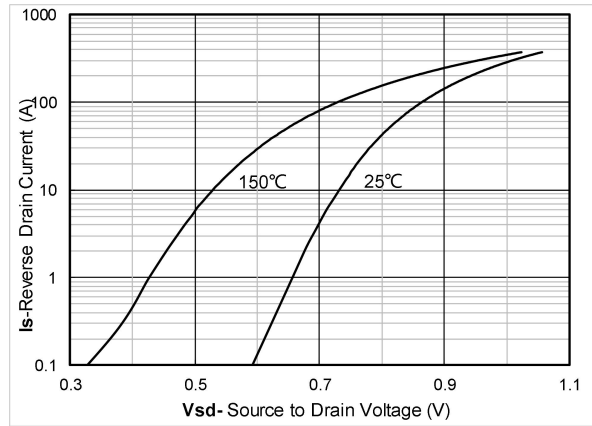


Figure 8. Forward characteristics of reverse diode

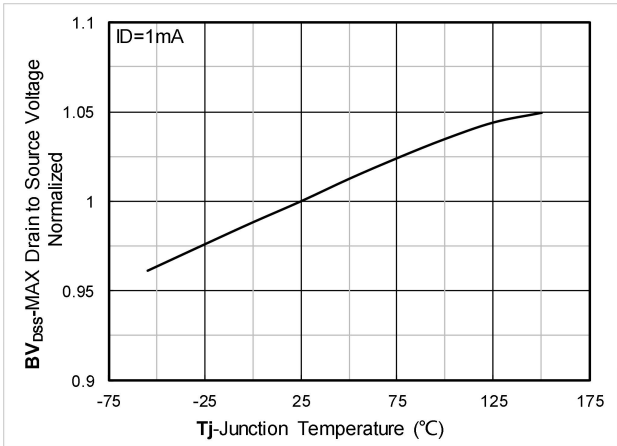


Figure 9. Normalized breakdown voltage

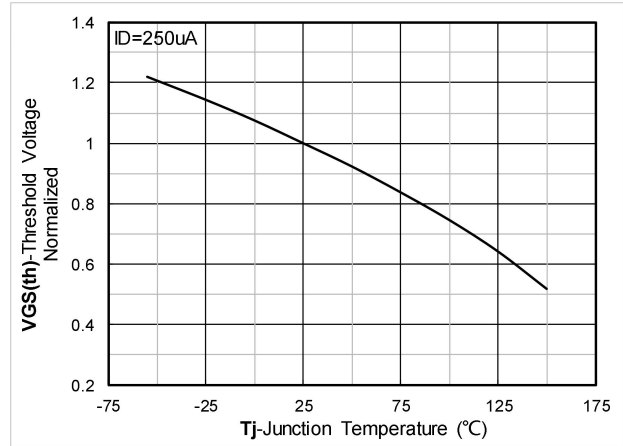


Figure 10. Normalized Threshold voltage

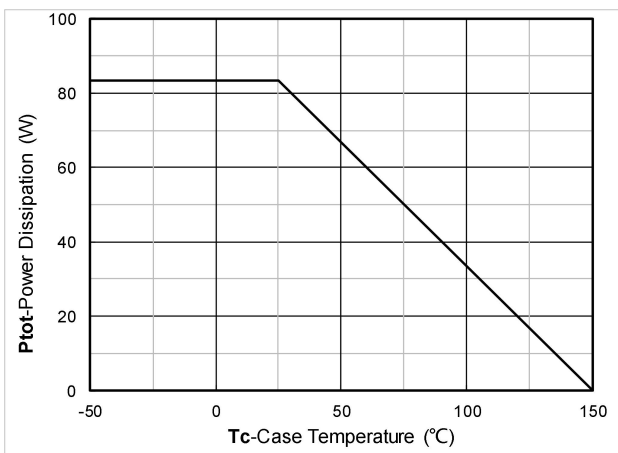


Figure 11. Power dissipation

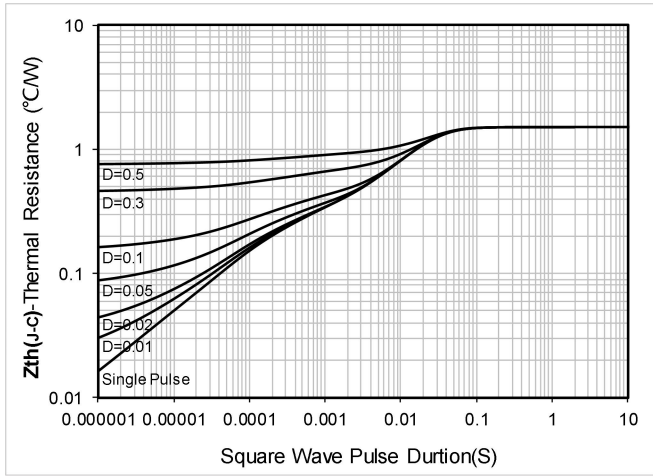


Figure 12. Maximum Transient Thermal Impedance

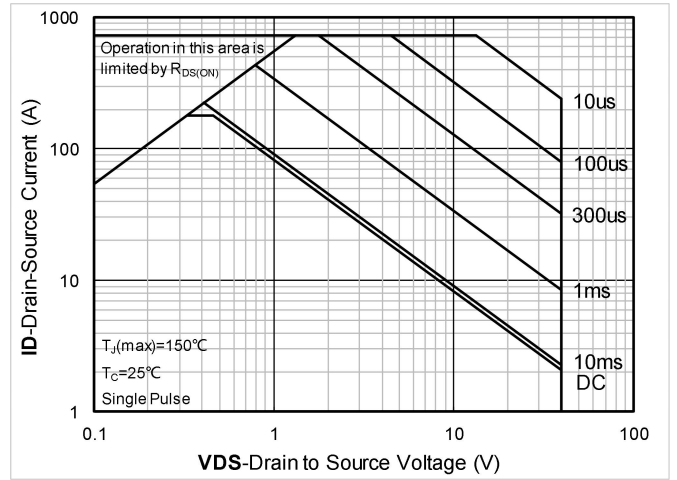
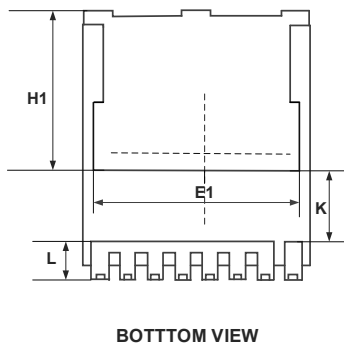
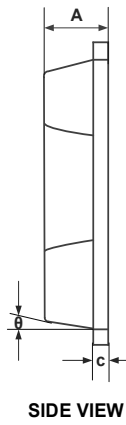
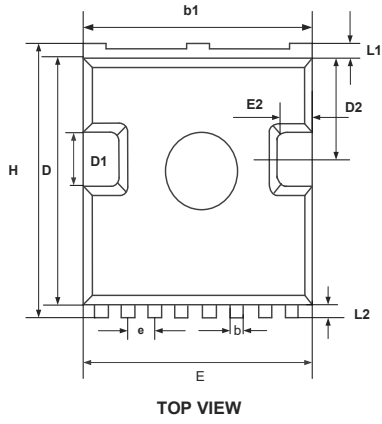


Figure 13. Safe Operation Area

Mechanical Dimensions for TOLL-8L

COMMON DIMENSIONS

SYMBOL	MM	
	MIN	MAX
A	2.20	2.40
b	0.60	0.90
b1	9.70	9.90
c	0.40	0.60
D	10.20	10.60
D1	3.10	3.50
D2	4.45	4.75
E	9.70	10.10
E1	7.80BSC	
E2	0.50	0.70
e	1.200 BSC	
H	11.45	11.90
H1	6.75 BSC	
K	3.10 REF	
L	1.70	2.10
L1	0.60	0.80
L2	0.50	0.70
θ	10° REF	

Attention

1, Any and all JGSEMI products described or contained herein do not have specifications that can handle applications that require extremely high levels of reliability, such as life-support systems, aircraft's control systems, or other applications whose failure can be reasonably expected to result in serious physical or material damage. Consult with your JGSEMI representative nearest you before using any JGSEMI products described or contained herein in such applications.

2, JGSEMI assumes no responsibility for equipment failures that result from using products at values that exceed, even momentarily, rated values (such as maximum ratings, operating condition ranges, or other parameters) listed in products specifications of any and all JGSEMI products described or contained herein.

3, Specifications of any and all JGSEMI products described or contained herein stipulate the performance, characteristics, and functions of the described products in the independent state, and are not guarantees of the performance, characteristics, and functions of the described products as mounted in the customer's products or equipment. To verify symptoms and states that cannot be evaluated in an independent device, the customer should always evaluate an d test devices mounted in the customer's products or equipment.

4, In the event that any or all JGSEMI products (including technical data, services) described or contained herein are controlled under any of applicable local export control laws and regulations, such products must not be exported without obtaining the export license from the authorities concerned in accordance with the above law.

5, No part of this publication may be reproduced or transmitted in any form or by any means, electronic or mechanical, including photocopying and recording, or any information storage or retrieval system, or otherwise, without the prior written permission of JGSEMI Semiconductor CO., LTD.

6, Any and all information described or contained herein are subject to change without notice due to product technology improvement, etc. When designing equipment, refer to the "Delivery Specification" for the JGSEMI product that you intend to use.