

## HT75XX-7 LOW DROPOUT LINEAR REGULATOR

### GENERAL DESCRIPTION

HT75XX-7 series are a set of Low Dropout Linear Regulator ICs implemented in CMOS technology. They can withstand voltage 30V. And they are available with low voltage drop and low quiescent current, widely used in audio, video and communication appliances.

### FEATURES

- Low Power Consumption
- Low Voltage Drop
- Low Temperature Coefficient
- Withstanding Voltage 30V
- Quiescent Current 1.5 $\mu$ A
- Output Voltage Accuracy: tolerance  $\pm 2\%$
- High output current: 100mA

### TYPICAL APPLICATIONS

- Battery-powered Equipments
- Communication Equipments
- Audio/Video Equipments

### PIN CONFIGURATION

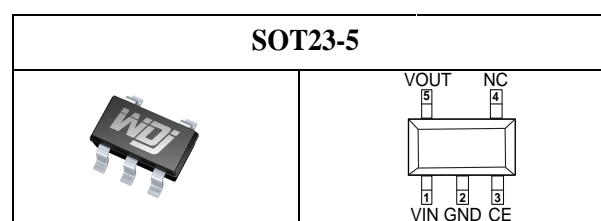
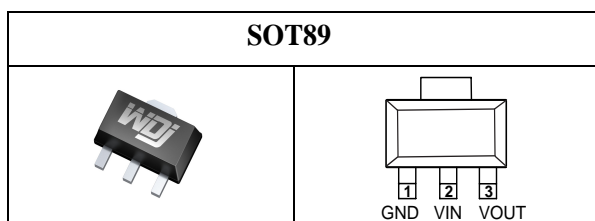

## OUTPUT

Series	Output	Package
HT7530-7	3.0V	SOT89 SOT23-5
HT7533-7	3.3V	
HT7550-7	5.0V	

**NOTE:** “XX” is output voltage.

## PIN DESCRIPTION

PIN No.		Name	Functions Description
SOT23-5	SOT89		
2	1	GND	ground
1	2	V <sub>IN</sub>	input
5	3	V <sub>OUT</sub>	output
3		CE	ON / OFF Control
4		NC	No Connect

## FUNCTIONAL BLOCK DIAGRAM

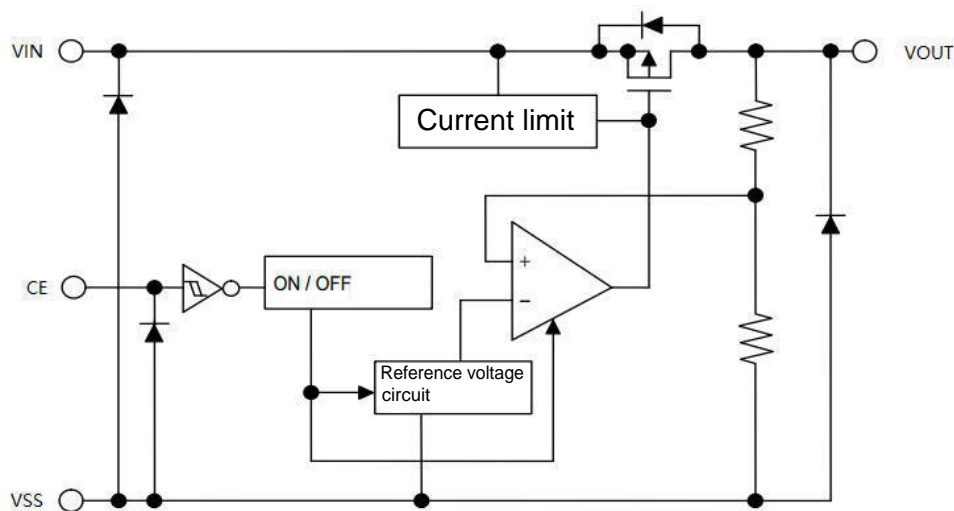

**ABSOLUTE MAXIMUM RATINGS**

Description	Symbol	Value range	Unit
Limit Power Voltage	V <sub>IN</sub>	-0.3~+33	V
Storage Temperature Range	T <sub>STG</sub>	-50~+125	°C
Operating Free-air Temperature Range	T <sub>A</sub>	-40~+85	°C

**Note :** Stresses greater than those listed under “Absolute Maximum Ratings” may cause permanent damage to the device. These are stress ratings only, and functional operation of the device at these or any other conditions beyond those indicated under “Recommended Operating Conditions” is not implied. Exposure to “Absolute Maximum Ratings” for extended periods may affect device reliability.

**HEAT DISSIPATION**

Description	Symbol	Package	Value range	Unit
Thermal resistance	$\theta_{JA}$	SOT89	200	°C/W
		SOT23-5	500	°C/W
Power dissipation	P <sub>W</sub>	SOT89	500	mW
		SOT23-5	200	mW

## DC CHARACTERISTICS (unless otherwise noted $T_A = +25^\circ\text{C}$ )

### Series HT7530-7

Parameter	Symbol	Test Condition	Min.	Typ.	Max.	Unit
Output Voltage	$V_{OUT}$	$V_{IN}=V_{OUT}+2.0V$ , $I_{OUT}=10mA$	2.94	3.00	3.06	V
Output Current	$I_{OUT}$	$V_{IN}=V_{OUT}+2.0V$	70	100	—	mA
Load Regulation	$\Delta V_{OUT}$	$V_{IN}=V_{OUT}+2.0V$ $1mA \leq I_{OUT} \leq 50mA$	—	25	60	mV
Voltage Drop	$V_{DIF}$	$I_{OUT}=1mA$ , $\Delta V_{OUT}=2\%$	—	30	100	mV
Quiescent Current	$I_{SS}$	No Load	—	1.5	2.5	$\mu A$
Line Regulation	$\frac{\Delta V_{OUT}}{V_{OUT}} / \frac{\Delta V_{IN}}{V_{IN}}$	$V_{OUT}+1.0V \leq V_{IN} \leq 30V$ , $I_{OUT}=1mA$	—	—	0.2	%/V
Input Voltage	$V_{IN}$	—	—	—	30	V
Temperature Coefficient	$\frac{\Delta V_{OUT}}{\Delta T_A} \cdot V_{OUT}$	$V_{IN}=V_{OUT}+2.0V$ , $I_{OUT}=10mA$ , $-40^\circ\text{C} \leq T_A \leq 85^\circ\text{C}$	—	100	—	ppm/ $^\circ\text{C}$

**Note :** When  $V_{IN}=V_{OUT}+2.0V$ , as the output voltage declined 2%, the  $V_{DIF}=V_{IN}-V_{OUT}$ .

### Series HT7533-7

Parameter	Symbol	Test Condition	Min.	Typ.	Max.	Unit
Output Voltage	$V_{OUT}$	$V_{IN}=V_{OUT}+2.0V$ , $I_{OUT}=10mA$	3.234	3.30	3.366	V
Output Current	$I_{OUT}$	$V_{IN}=V_{OUT}+2.0V$	70	100	—	mA
Load Regulation	$\Delta V_{OUT}$	$V_{IN}=V_{OUT}+2.0V$ $1mA \leq I_{OUT} \leq 50mA$	—	25	60	mV
Voltage Drop	$V_{DIF}$	$I_{OUT}=1mA$ , $\Delta V_{OUT}=2\%$	—	25	55	mV
Quiescent Current	$I_{SS}$	No Load	—	1.5	2.5	$\mu A$
Line Regulation	$\frac{\Delta V_{OUT}}{V_{OUT}} / \frac{\Delta V_{IN}}{V_{IN}}$	$V_{OUT}+1.0V \leq V_{IN} \leq 30V$ , $I_{OUT}=1mA$	—	—	0.2	%/V
Input Voltage	$V_{IN}$	—	—	—	30	V
Temperature Coefficient	$\frac{\Delta V_{OUT}}{\Delta T_A} \cdot V_{OUT}$	$V_{IN}=V_{OUT}+2.0V$ , $I_{OUT}=10mA$ , $-40^\circ\text{C} \leq T_A \leq 85^\circ\text{C}$	—	100	—	ppm/ $^\circ\text{C}$

**Note :** When  $V_{IN}=V_{OUT}+2.0V$ , as the output voltage declined 2%, the  $V_{DIF}=V_{IN}-V_{OUT}$ .

## Series HT7550-7

Parameter	Symbol	Test Condition	Min.	Typ.	Max.	Unit
Output Voltage	$V_{OUT}$	$V_{IN}=V_{OUT}+2.0V$ , $I_{OUT}=10mA$	4.9	5.0	5.1	V
Output Current	$I_{OUT}$	$V_{IN}=V_{OUT}+2.0V$	100	150	—	mA
Load Regulation	$\Delta V_{OUT}$	$V_{IN}=V_{OUT}+2.0V$ $1mA \leq I_{OUT} \leq 70mA$	—	25	60	mV
Voltage Drop	$V_{DIF}$	$I_{OUT}=1mA$ , $\Delta V_{OUT}=2\%$	—	25	55	mV
Quiescent Current	$I_{SS}$	No Load	—	1.5	2.5	$\mu A$
Line Regulation	$\frac{\Delta V_{OUT}}{V_{OUT}} \cdot \frac{\Delta V_{IN}}{\Delta V_{IN}}$	$V_{OUT}+1.0V \leq V_{IN} \leq 30V$ , $I_{OUT}=1mA$	—	—	0.2	%/V
Input Voltage	$V_{IN}$	—	—	—	30	V
Temperature Coefficient	$\frac{\Delta V_{OUT}}{\Delta T_A} \cdot V_{OUT}$	$V_{IN}=V_{OUT}+2.0V$ , $I_{OUT}=10mA$ , $-40^\circ C \leq T_A \leq 85^\circ C$	—	100	—	ppm/ $^\circ C$

**Note :** When  $V_{IN}=V_{OUT}+2.0V$ , as the output voltage declined 2%, the  $V_{DIF}=V_{IN}-V_{OUT}$ .

## FUNCTIONAL DESCRIPTION

HT75XX-7 series are linear voltage regulator ICs withstanding 30V voltage. The series IC consists of a voltage reference, an error amplifier, a current limiter and a phase compensation circuit plus a driver transistor. The output stabilization capacitor is also compatible with low ESR ceramic capacitors.

The over current protection circuit and the over voltage protection circuit are built-in. The protection circuit will operate when the output current or input voltage reaches limit level.

## TYPICAL APPLICATION CIRCUIT

### Basic Circuit

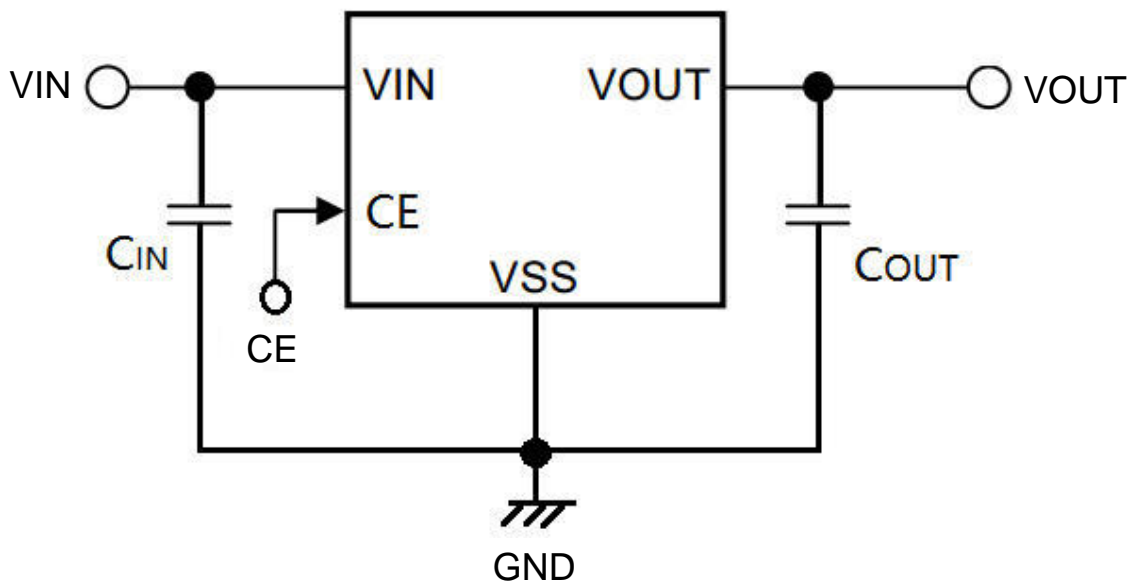

## PACKAGE INFORMATION

SOT89

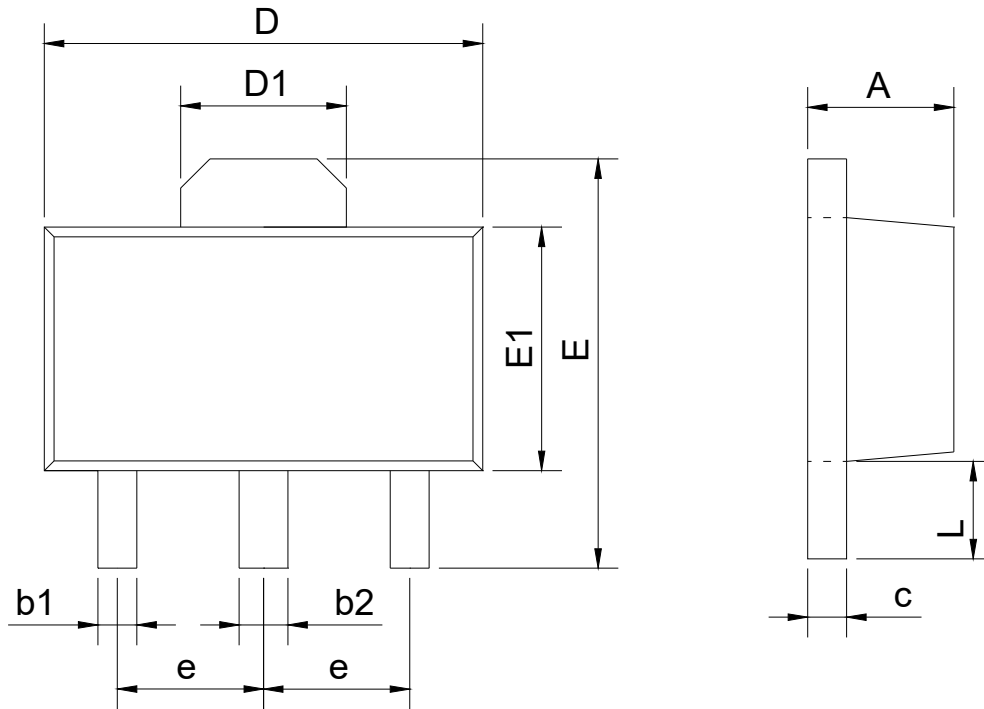

SYMBOL	mm	
	min	max
A	1.40	1.60
b1	0.35	0.50
b2	0.45	0.60
c	0.36	0.46
D	4.30	4.70
D1	1.40	1.80
E	4.00	4.40
E1	2.30	2.70
e	1.50BSC	
L	0.80	1.20

## SOT23-5

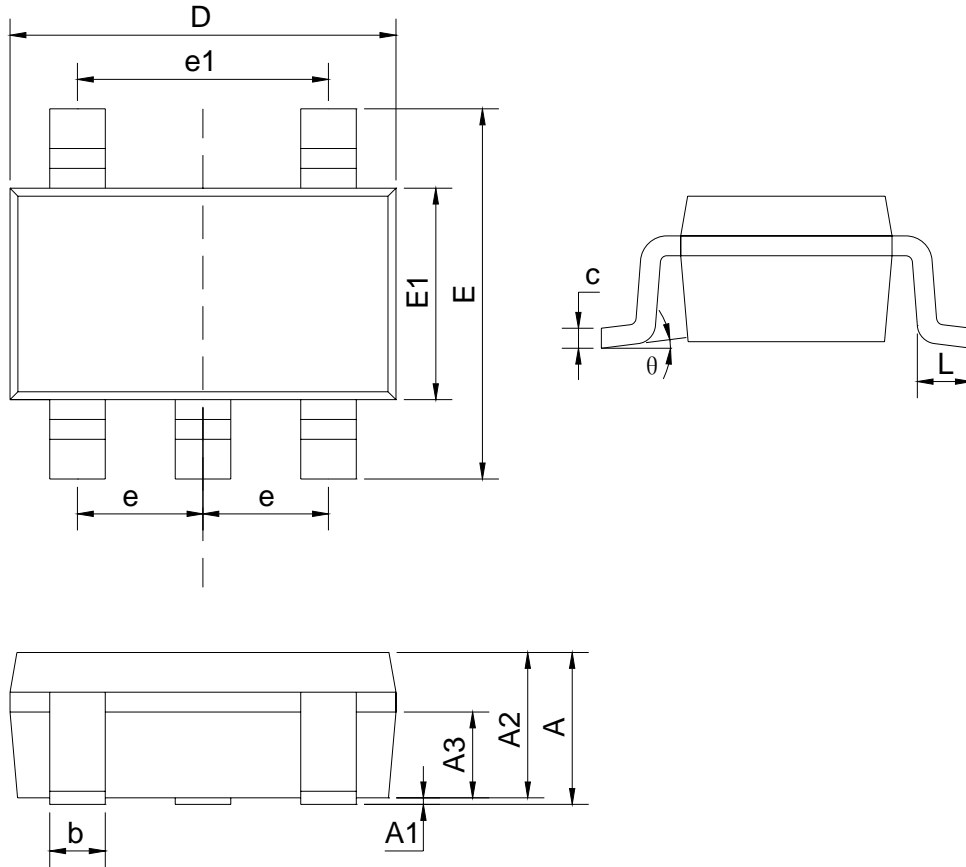

SYMBOL	mm	
	min	max
A		1.35
A1	0.04	0.15
A2	1.00	1.20
A3	0.55	0.75
b	0.38	0.48
c	0.10	0.25
D	2.72	3.12
E	2.60	3.00
E1	1.40	1.80
e	0.95BSC	
e1	1.90BSC	
L	0.30	0.60
$\theta$	0	8°