

一、概述

●电容器及介质种类：

※高频类： 此类介质材料的电容器为 I 类电容器，包括通用型高频 COG、COH 电容器和温度补偿型高频 HG、LG、PH、RH、SH、TH、UJ、SL 电容器。其中 COG、COH 电容器电性能最稳定，几乎不随温度、电压和时间的变化而变化，适用于低损耗，稳定性要求高的高频电路，HG、LG、PH、RH、SH、TH、UJ、SL 电容器容量随温度变化而相应变化，适用于低损耗、温度补偿型电路中。

※ X7R、X5R： 此类介质材料的电容器为 II 类电容器，具有较高的介电常数，容量比 I 类电容器高，具有较稳定的温度特性，适用于容量范围广，稳定性要求不高的电路中，如隔直、耦合、旁路、鉴频等电路中。

※Y5V： 此类介质材料的电容器为 II 类电容器，是所有电容器中介电常数最大的电容器，但其容量稳定性较差，对温度、电压等条件较敏感，适用于要求大容量，温度变化不大的电路中。

※Z5U： 此类介质材料的电容器为 II 类电容器，其温度特性介于 X7R 和 Y5V 之间，容量稳定性较差，对温度、电压等条件较敏感，适用于要求大容量，使用温度范围接近于室温的旁路，耦合等，低直流偏压的电路中。

SUMMARY

●Types of Dielectric Material and Capacitor

※HIGH FREQUENCY TYPE: The capacitor of this kind dielectric material is considered as Class I capacitor, including high frequency COG、COH capacitor and temperature compensating capacitor such as HG, LG, PH, RH,SH, TH, UJ, SL. The electrical properties of COG、COH capacitor are the most stable one and change invariably with temperature, voltage and time. They are suited for applications where low-losses and high-stability are required, HG, LG, PH, RH, SH, TH, UJ, SL capacitor's capacitance changes with temperature. They are suited for applications where low-losses and temperature compensating circuits.

※X7R、X5R: X7R、X5R material is a kind of material has high dielectric constant. The capacitor made of this kind material is considered as Class II capacitor whose capacitance is higher than that of class I. These capacitors are classified as having a semi-stable temperature characteristic and used over a wide temperature range, such in these kinds of circuits, DC-blocking, decoupling, bypassing, frequency discriminating etc.

※Y5V: The capacitor made of this kind of material is the highest dielectric constant of all ceramic capacitors. They are used over a moderate temperature range in application where high capacitance is required because of its unstable temperature coefficient, but where moderate losses and capacitance changes can be tolerated. Its capacitance and dissipation factors are sensible to measuring conditions, such as temperature and voltage, etc.

※Z5U: The capacitor made of this kind of material is considered as Class II capacitor, whose temperature characteristic is between that of X7R and Y5V. The capacitance of this kind of capacitor is unstable and sensible to temperature and voltage. Ideally suited for bypassing and decoupling application circuits operating with low DC bias in the environment approaches to room temperature.

二、结构及尺寸 STRUCTURE AND DIMENSIONS

※ 尺寸 DIMENSIONS

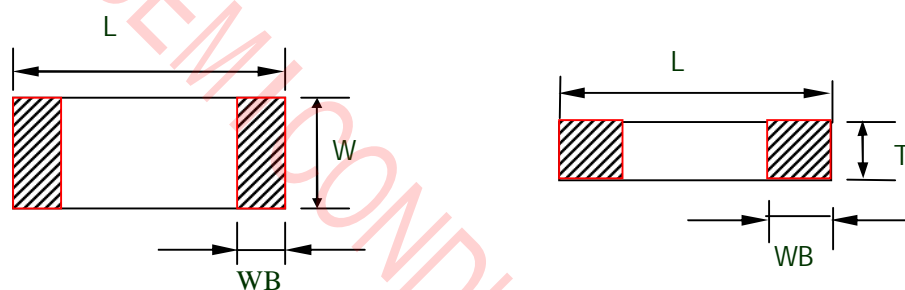

型号 Type		尺寸 Dimensions (mm)			
英制表示 British expression	公制表示 Metric expression	L	W	T	WB
0402	1005	1.00±0.05	0.50±0.05	0.50±0.05	0.25±0.10
0603	1608	1.60±0.10	0.80±0.10	0.80±0.10	0.30±0.10
0805	2012	2.00±0.20	1.25±0.20	≤0.55 0.80±0.20 1.00±0.20 1.25±0.20	0.50±0.20
1206	3216	3.20±0.30	1.60±0.30	0.80±0.20 1.00±0.20 1.25±0.20 1.60±0.30	0.60±0.30
1210	3225	3.20±0.30	2.50±0.30	≤2.80	0.80±0.30
1808	4520	4.50±0.40	2.00±0.20	≤2.20	0.80±0.30
1812	4532	4.50±0.40	3.20±0.30	≤3.50	0.80±0.30
2225/2220	5763	5.70±0.50	6.30±0.50	≤6.20	1.00±0.40
3035	7690	7.60±0.50	9.00±0.50	≤8.10	1.00±0.40

备注：可根据客户的特殊要求设计符合客户需求的产品。

Note: We can design according to customer special requirements

※ 结构 STRUCTURE

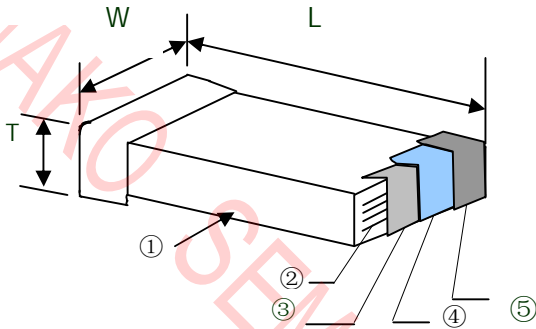

序号 NO	名称 Name
①	陶瓷介质 Ceramic dielectric
②	内电极 Inner electrode
③	外电极 Substrate electrode
④	镍层 Nickel Layer
⑤	锡层 Tin Layer

三、型号规格表示方法 HOW TO ORDER

<u>0805</u>	<u>CG</u>	<u>101</u>	<u>J</u>	<u>500</u>	<u>N</u>	<u>T</u>
①	②	③	④	⑤	⑥	⑦

※说明 NOTES:

①尺寸 DIMENSIONS

单位 (unit): inch/ mm

尺寸规格 SizeCode	0402	0603	0805	1206	1210	1808	1812	2225/2220	3035
长×宽 (L×W) inch	0.04×0.02	0.06×0.03	0.08×0.05	0.12×0.06	0.12×0.10	0.18×0.08	0.18×0.12	0.22×0.25	0.30×0.35
长×宽 (L×W) mm	1.00×0.50	1.60×0.80	2.00×1.25	3.20×1.60	3.20×2.50	4.50×2.00	4.50×3.20	5.70×6.30	7.60×9.00

② 介质种类 DIELECTRIC STYLE

介质种类 (Dielectric Code)	CG	CH	HG	LG	PH	RH	SH	TH	UJ	SL	X	B	E	F
介质材料 (Dielectric)	COG	COH	HG	LG	PH	RH	SH	TH	UJ	SL	X5R	X7R	Z5U	Y5V

版本号

MK2008-001

③ 标称容量 NOMINAL CAPACITANCE

单位(unit): pF

表示方式 (Express Method)	实际值 (Actual Value)	
0R5	0.5	注：头两位数字为有效数字，第三位数字为 0 的个数；R 为小数点。 Note: the first two digits are significant; third digit denotes number of zeros; R=decimal point.
1R0	1.0	
102	10×10^2	
224	22×10^4	
...	...	

④ 容量误差 CAPACITANCE TOLERANCE

代码 (Code)	B	C	D	F	G	J	K	M	S	Z
误差 (Tolerance)	± 0.10pF	± 0.25pF	±0.5pF	±1.0%	±2.0%	±5.0%	±10%	±20%	+50% -20%	+80% -20%

备注：B、C、D 级误差适用于容量 ≤ 10pF 的产品。

Note: These capacitance tolerance B, C, D are just applicable the capacitance that equals to or less than 10pF.

⑤ 额定电压 RATED VOLTAGE

单位(unit): V

表示方式 (Express Method)	实际值 (Actual Value)	
6R3	6.3	注：头两位数字为有效数字，第三位数字为 0 的个数； R 为小数点。 Note: the first two digits are significant; third digit denotes number of zeros; R=decimal point.
500	50×10^0	
201	20×10^1	
102	10×10^2	
...	...	

⑥ 端头材料 TERMINAL MATERIAL STYLES

端头类别 (Termination Styles)	表示方式 (Express Method)
纯银端头 (Silver Solderable Termination)	S
纯铜端头 (Copper Solderable Termination)	C
三层电镀端头 (Nickel Barrier Termination)	N

⑦ 包装方式 PACKAGE STYLES

B	T
散包装 (Bulk Bag)	编带包装 (Taping Package)

四、温度系数/特性 Temperature Coefficient /Characteristics

介质种类 Dielectric	参考温度点 Reference Temperature Point	标称温度系数 Temperature Coefficient	工作温度范围 Operation Temperature Range
COG	20°C	0±30 ppm/°C	-55°C ~ 125°C
COH	20°C	0±60 ppm/°C	-55°C ~ 125°C
HG	20°C	-33±30 ppm/°C	-25°C ~ 85°C
LG	20°C	-75±30 ppm/°C	-25°C ~ 85°C
PH	20°C	-150± 60 ppm/°C	-25°C ~ 85°C
RH	20°C	-220± 60 ppm/°C	-25°C ~ 85°C
SH	20°C	-330± 60 ppm/°C	-25°C ~ 85°C
TH	20°C	-470± 60 ppm/°C	-25°C ~ 85°C
UJ	20°C	-750± 120 ppm/°C	-25°C ~ 85°C
SL	20°C	-1000~+140 ppm/°C	-25°C ~ 85°C
X7R	20°C	±15%	-55°C ~ 125°C
X5R	20°C	±15%	-55°C ~ 85°C
Z5U	20°C	-56% ~ +22%	10°C ~ 85°C
Y5V	20°C	-80% ~ +30%	-25°C ~ 85°C

备注：I 类电容器标称温度系数和允许偏差是采用温度在 20°C 和 85°C 之间的电容量变化来确定的，而 II 类电容器标称温度系数是按照工作范围之间的电容量相对 20°C 的电容量变化来确定的。

Note: Nominal temperature coefficient and allowed tolerance of class I are decided by the changing of the capacitance between 20°C and 85°C. Nominal temperature coefficient of class II are decided by the temperature of 20°C.

五、容量范围及其电压 Capacitance Range and Operating Voltage

单位/unit: pF

尺寸规格 Size Code	额定电压 Rated Voltage	容量范围 Capacitance		
		COG (NPO)	X7R (X5R)	Y5V (Z5U)
0402	10V	0.1~470	100~4,700,000	1,000~1,000,000
	16V	0.1~470	100~1,000,000	1,000~1,000,000
	25V	0.1~470	100~47,000	1,000~220,000
	35V	0.1~470	100~22,000	1,000~100,000
	50V	0.1~470	100~47000,000	100~47000,000
0603	10V	0.1~4,700	100~47000,000	100~47000,000
	16V	0.1~4,700	100~47000,000	100~47000,000
	25V	0.1~4,700	100~47000,000	100~47000,000
	35V	0.1~4,700	100~47000,000	100~47000,000
	50V	0.1~4,700	100~47000,000	100~47000,000
0805	10V	0.3~10,000	100~100,000,000	100~100,000,000
	16V	0.3~10,000	100~100,000,000	100~100,000,000
	25V	0.3~10,000	100~100,000,000	100~100,000,000
	35V	0.3~10,000	100~100,000,000	100~100,000,000
	50V	0.3~10,000	100~100,000,000	100~100,000,000
1206	10V	0.5~33,000	100~100,000,000	100~100,000,000
	16V	0.5~33,000	100~100,000,000	100~100,000,000
	25V	0.5~33,000	100~100,000,000	100~100,000,000
	35V	0.5~33,000	100~100,000,000	100~100,000,000
	50V	0.5~12,000	100~100,000,000	1,000~100,000,000
1210	10V	10~10,000	100~100,000,000	100~100,000,000
	16V	10~10,000	100~100,000,000	100~100,000,000
	25V	10~10,000	100~100,000,000	100~100,000,000
	35V	10~10,000	100~100,000,000	100~100,000,000
	50V	10~8,200	100~100,000,000	100~100,000,000

单位/unit: pF

尺寸规格 Size Code	额定电压 Rated Voltage	容量范围 Capacitance		
		COG (NPO)	X7R (X5R)	Y5V (Z5U)
1808	10V	10~10,000	100~100,000,000	100~100,000,000
	16V	10~10,000	100~100,000,000	100~100,000,000
	25V	10~10,000	100~100,000,000	100~100,000,000
	35V	10~10,000	100~100,000,000	100~100,000,000
	50V	10~6,800	100~100,000,000	100~100,000,000
1812	10V	10~15,000	100~100,000,000	100~100,000,000
	16V	10~15,000	100~100,000,000	100~100,000,000
	25V	10~15,000	100~100,000,000	100~100,000,000
	35V	10~15,000	100~100,000,000	100~100,000,000
	50V	10~12,000	100~100,000,000	100~100,000,000
2225/2220	10V	10~4,700,0000	100~100,000,000	100~100,000,000
	16V	10~4,700,0000	100~100,000,000	100~100,000,000
	25V	10~4,700,0000	100~100,000,000	100~100,000,000
	35V	10~4,700,0000	100~100,000,000	100~100,000,000
	50V	10~3,300,000	100~100,000,000	100~100,000,000
3035	10V	10~100,000	100~100,000,000	100~100,000,000
	16V	10~100,000	100~100,000,000	100~100,000,000
	25V	10~100,000	100~100,000,000	100~100,000,000
	35V	10~100,000	100~100,000,000	100~100,000,000
	50V	10~47,000	100~100,000,000	100~100,000,000

备注：可根据客户的特殊要求设计符合客户需求的产品。

Note: We can design according to customer special requirements

六、高 Q 值 COG 电容器 Hi-Q COG MLCC

●应用:

适合于射频 RF 电路及要求 Hi-Q、低 ESR、高频率响应的微波电路中。

●CQ、CG 电容器说明:

※下述 Q 值标准是相对通用客户而制定的, 对要求更高 Q 值产品的客户, 可专门设计和生产。

※使用频率在 1MHz~2.4GHz 之间, 对要求更高频率产品的客户, 可根据客户的要求另外专门设计。

※CQ 比 CG 相对可应用频率略高, 请客户按需选定。

●Application:

Hi-Q COG capacitors are ideally suited for RF and microwave application requiring high Q, low ESR, and high resonant frequency。

●Note for CQ and CG:

※The following Q value is just confirmed by general customer. If there is a higher requirement for Q value requirements, we can design and produce according to the special requirements。

※For the customer whose requirements for frequency is between 1MHz and 2.4GHz or higher frequency, we can design it according to their requirements。

※The frequency of CQ is a little higher than that of CG. Please choose them according to your requirements。

● CQ 电容器的容量值及其 Q 值 CQ Capacitance value and Q value

容量 Capacitance (pF)	300MHz 时的Q 值 Q value at 300MHz		容量 Capacitance (pF)	300MHz 时的Q 值 Q value at 300MHz		容量 Capacitance (pF)	300MHz 时的Q 值 Q value at 300MHz	
	0805	0603		0805	0603		0805	0603
4.7	1000	800	11	450	360	24	200	160
5.2	900	720	12	400	320	27	175	140
5.6	850	680	13	375	300	30	150	120
6.2	800	640	14	350	280	33	140	112
6.8	700	560	15	325	260	36	130	104
7.5	650	520	16	300	240	39	120	96
8.2	575	460	18	250	200	43	110	88
9.1	525	420	20	225	180	47	100	80
10	500	400	22	215	172	----	----	----

七、中高压电容器 HIGH VOLTAGE MLCC

中高压多层片状陶瓷电容器是在多层片状陶瓷电容器的工艺技术、设备基础上，通过采用特殊工艺制作的一种具有良好高压可靠性的产品，该产品适合于表面贴装，适合于多种直流高压线路，可以有效的改善电子线路的性能。

●应用范围

- ※模拟或数字调制解调器。
- ※局域网/广域网接口界面。
- ※日光灯启动辉器照明电路。
- ※倍压电器。
- ※直流变送器。
- ※背光源驱动电路。

Middle & high voltage MLCC is a kind of special design 、 special technology MLCC that bases on the technology of general MLCC. This kind of MLCC has stable high voltage reliability and suitable to SMT. Middle & high MLCC is widely applicable for many direct high voltage circuits in which it can improve the performance of the circuit.

●APPLICATIONS

- ※Analog & Digital Modems
- ※LAN/WAN Interface
- ※Lighting Ballast Circuits
- ※Voltage Multipliers
- ※DC-DC Converters
- ※Back-lighting Inverters

容量范围及其电压

单位/unit: pF

尺寸规格 Size Code	工作电压 Rated Voltage	容量范围 Capacitance		
		NPO	X7R	Y5V
0603	100V	0.5~820	150~10,000	2,200~68,000
	200V	0.5~470	150~6,800	-----
	250V	0.5~470	150~6,800	-----
0805	100V	0.5~1,500	150~3300,000	10,000~100,000
	200V	0.1~1,500	150~22,000	10,000~56,000
	250V	0.1~1,500	150~22,000	10,000~56,000
	500V	0.1~560	150~100,0000	-----
	1000V	0.1~100	-----	-----
1206	100V	0.5~3,300	150~100,000	15,000~330,000
	200V	0.1~2,700	150~47,000	10,000~150,000
	250V	0.1~2,700	150~33,000	10,000~150,000
	500V	0.1~1,500	150~22,000	-----
	1000V	0.1~1,000	150~5,600	-----
	2000V	0.1~270	150~1,500	-----
1210	100V	1.0~4,700	150~220,000	10,000~820,000
	200V	1.0~3,300	150~100,000	10,000~390,000
	250V	1.0~3,300	150~82,000	10,000~390,000
	500V	1.0~2,000	150~33,000	-----
	1000V	1.0~820	150~10,000	-----
	2000V	1.0~470	150~6,800	-----
1808	100V	2.0~4,700	150~220,000	150,000~1,000,000
	200V	2.0~3,300	150~100,000	10,000~390,000
	250V	2.0~3,300	150~82,000	10,000~390,000
	500V	2.0~1,800	150~39,000	-----
	1000V	2.0~820	150~10,000	-----
	2000V	2.0~470	150~6,800	-----
	3000V	2.0~470	150~2,200	-----
	4000V	2.0~56	150~1,000	-----
	5000V	2.0~27	-----	-----

版本号

MK2008-001

容量范围及其电压

单位/unit: pF

尺寸规格 Size Code	工作电压 Rated Voltage	容量范围 Capacitance (PF)		
		NPO	X7R	Y5V
1812	100V	3.0~180 220~10,000	150~330,000	150,000~1,500,000
	200V	3.0~5,600	150~150,000	100,000~470,000
	250V	3.0~5,600	150~120,000	100,000~470,000
	500V	3.0~3,900	150~100,000	-----
	1000V	3.0~1,200	150~27,000	-----
	2000V	3.0~680	150~10,000	-----
	3000V	3.0~470	150~2,200	-----
	4000V	3.0~220	150~1,500	-----
	5000V	3.0~56	-----	-----
2225/2220	100V	5.0~27,000	150~1,000,000	250,000~3,300,000
	200V	5.0~12,000	150~470,000	22,000~680,000
	250V	5.0~12,000	150~470,000	22,000~680,000
	500V	5.0~6,800	150~330,000	-----
	1000V	5.0~2,200	150~56,000	-----
	2000V	5.0~1,000	150~27,000	-----
	3000V	5.0~680	150~3,900	-----
	4000V	5.0~560	150~3,300	-----
	5000V	5.0~100	-----	-----

备注：可根据客户的特殊要求设计符合客户需求的产品。

Note: We can design according to customer special requirements

版本号	MK2008-001		
-----	------------	--	--

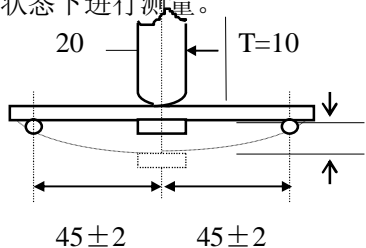
项目 Item	技术规格 Technical Specification	测试方法 Test Method and Remarks																														
抗弯曲强度 Resistance to Flexure of Substrate (Bending Strength)	外观：无可见损伤。 Appearance: No visible damage.	<p>试验基板：Al₂O₃或PCB 弯曲深度：1mm 施压速度：0.5mm/sec. 单位：mm 应在弯曲状态下进行测量。</p>  <p>45 ± 2 45 ± 2</p>																														
	Δ C/C ≤ ± 10%	<p>Test Board: Al₂O₃ or PCB Warp: 1mm Speed: 0.5mm/sec. Unit: mm The measurement should be made with the board in the bending position.</p>																														
端头结合强度 Termination Adhesion	外观无可见损伤 No visible damage.	<p>施加的力：5N 时间：10 ± 1S Applied Force: 5N Duration: 10 ± 1S</p>																														
温度循环 Temperature Cycle	<p>Δ C/C: I类： ≤ ± 1%或 ± 1pF, 取两者中最大者 II类： B: ≤ ± 10% E,F: ≤ ± 20%</p> <p>Class I : ≤ ± 1% or ± 1pF, whichever is larger. Class II : B: ≤ ± 10% E,F: ≤ ± 20%</p>	<p>预处理* (2类)： 上限类别温度，1小时 恢复：24 ± 1h 初始测量 循环次数：5次，一个循环分以下4步：</p> <table border="1"> <thead> <tr> <th>阶段</th> <th>温度 (°C)</th> <th>时间 (分钟)</th> </tr> </thead> <tbody> <tr> <td>第1步</td> <td>下限温度^{(NPO/XTR: -55) (YSV:25 ZSU:±10)}</td> <td>30</td> </tr> <tr> <td>第2步</td> <td>常温 (+20)</td> <td>2~3</td> </tr> <tr> <td>第3步</td> <td>上限温度^{(NPO/XTR: +125) (YSV/ZSU: +85)}</td> <td>30</td> </tr> <tr> <td>第4步</td> <td>常温 (+20)</td> <td>2~3</td> </tr> </tbody> </table> <p>试验后放置 (恢复) 时间：24 ± 2h Preheating conditions: up-category temperature, 1h Recovery time: 24 ± 1h Initial Measurement Cycling Times: 5 times, 1 cycle, 4 steps:</p> <table border="1"> <thead> <tr> <th>Step</th> <th>Temperature (°C)</th> <th>Time (min.)</th> </tr> </thead> <tbody> <tr> <td>1</td> <td>Low- category temp. ^{(NPO/XTR: -55) (YSV:25 ZSU:±10)}</td> <td>30</td> </tr> <tr> <td>2</td> <td>Normal temp. (+20)</td> <td>2~3</td> </tr> <tr> <td>3</td> <td>Up- category temp. ^{(NPO/XTR: +125) (YSV/ZSU: +85)}</td> <td>30</td> </tr> <tr> <td>4</td> <td>Normal temp. (+20)</td> <td>2~3</td> </tr> </tbody> </table> <p>Recovery time after test: 24 ± 2h</p>	阶段	温度 (°C)	时间 (分钟)	第1步	下限温度 ^{(NPO/XTR: -55) (YSV:25 ZSU:±10)}	30	第2步	常温 (+20)	2~3	第3步	上限温度 ^{(NPO/XTR: +125) (YSV/ZSU: +85)}	30	第4步	常温 (+20)	2~3	Step	Temperature (°C)	Time (min.)	1	Low- category temp. ^{(NPO/XTR: -55) (YSV:25 ZSU:±10)}	30	2	Normal temp. (+20)	2~3	3	Up- category temp. ^{(NPO/XTR: +125) (YSV/ZSU: +85)}	30	4	Normal temp. (+20)	2~3
阶段	温度 (°C)	时间 (分钟)																														
第1步	下限温度 ^{(NPO/XTR: -55) (YSV:25 ZSU:±10)}	30																														
第2步	常温 (+20)	2~3																														
第3步	上限温度 ^{(NPO/XTR: +125) (YSV/ZSU: +85)}	30																														
第4步	常温 (+20)	2~3																														
Step	Temperature (°C)	Time (min.)																														
1	Low- category temp. ^{(NPO/XTR: -55) (YSV:25 ZSU:±10)}	30																														
2	Normal temp. (+20)	2~3																														
3	Up- category temp. ^{(NPO/XTR: +125) (YSV/ZSU: +85)}	30																														
4	Normal temp. (+20)	2~3																														

九、包装 PACKAGE

●纸带卷盘结构 PAPER TAPING

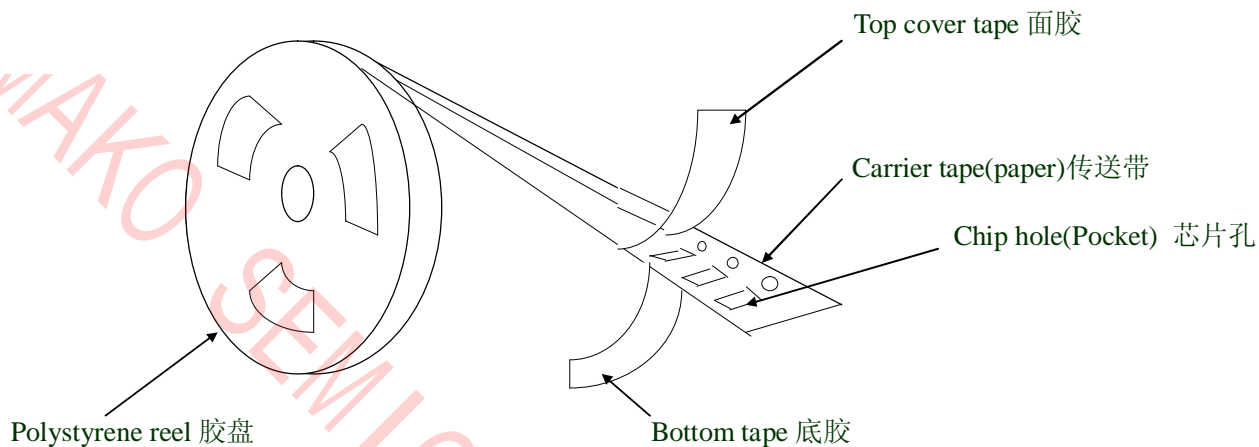

※0402 纸带编带尺寸大小

Dimensions of paper taping for 0402 type

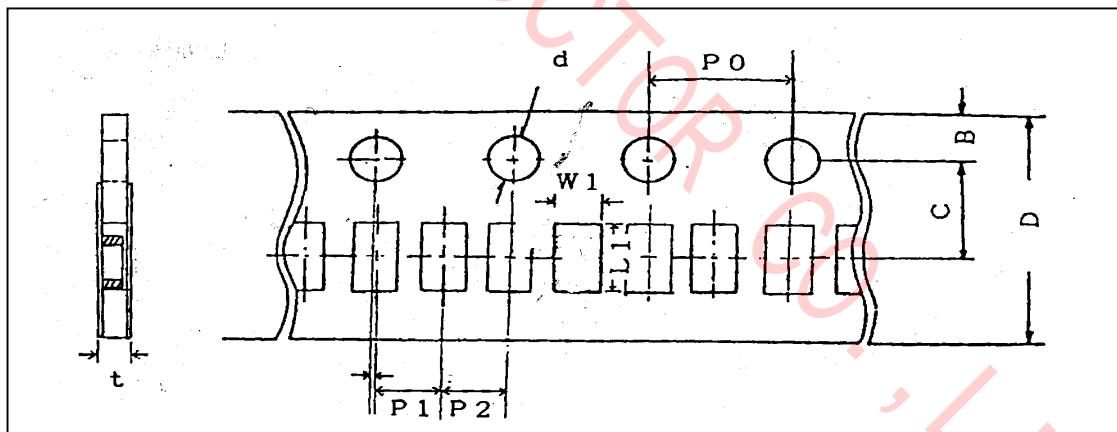

代号 Code	W1	L1	D	C	B	P1	P2	P0	d	t
0402	0.65±0.20	1.15±0.20	8.00±0.20	3.50±0.05	1.75±0.10	2.00±0.05	2.00±0.05	4.00±0.10	1.50 -0/+0.10	0.80 Below

版本号

MK2008-001

※适合 ‘0603, 0805, 1206’ 常规尺寸产品的纸带尺寸
Dimensions of paper taping for 0603, 0805, 1206 types.

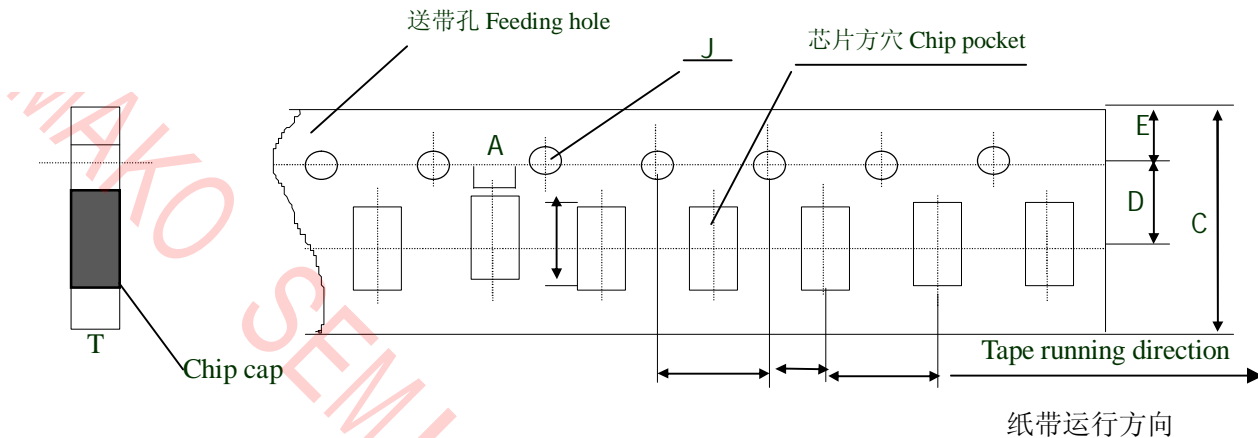

Unit: mm

代号 Code 纸带规格 paper size	A	B	C	D*	E	F	G*	H	J	T
0603	1.10 ±0.20	1.90 ±0.20	8.00 ±0.20	3.50 ±0.05	1.75 ±0.10	4.00 ±0.10	2.00 ±0.10	4.00 ±0.10	1.50 -0/+0.10	1.10 Max
0805	1.45 ±0.20	2.30 ±0.20	8.00 ±0.20	3.50 ±0.05	1.75 ±0.10	4.00 ±0.10	2.00 ±0.10	4.00 ±0.10	1.50 -0/+0.10	1.10 Max
1206	1.80 ±0.20	3.40 ±0.20	8.00 ±0.20	3.50 ±0.05	1.75 ±0.10	4.00 ±0.10	2.00 ±0.10	4.00 ±0.10	1.50 -0/+0.10	1.10 Max

注意：*表示此处对尺寸的要求非常精确。

Note: The place with "*" means where needs exactly dimensions.

● 塑胶卷盘结构 EMBOSSED TAPING

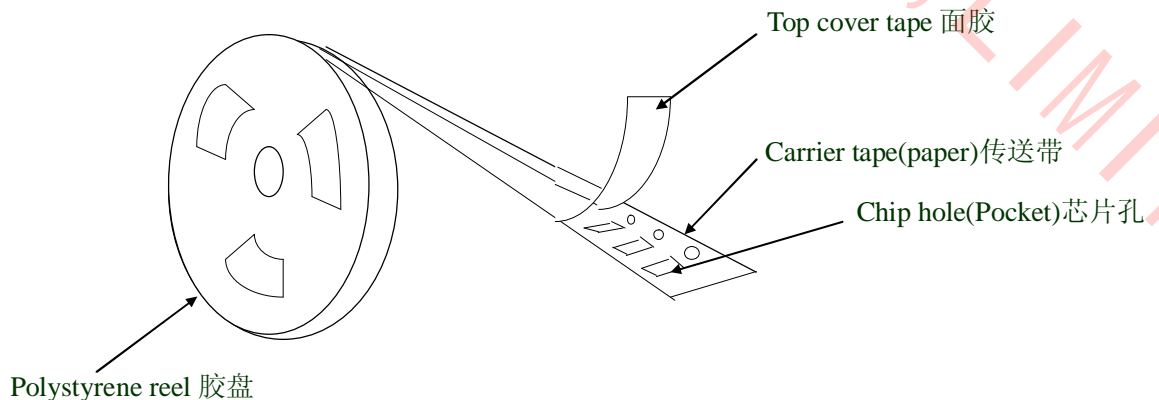

版本号

MK2008-001

※ 塑胶带尺寸结构(适合 ‘0805~1812’ 型产品)

Dimensions of embossed taping for 0805~1812 type

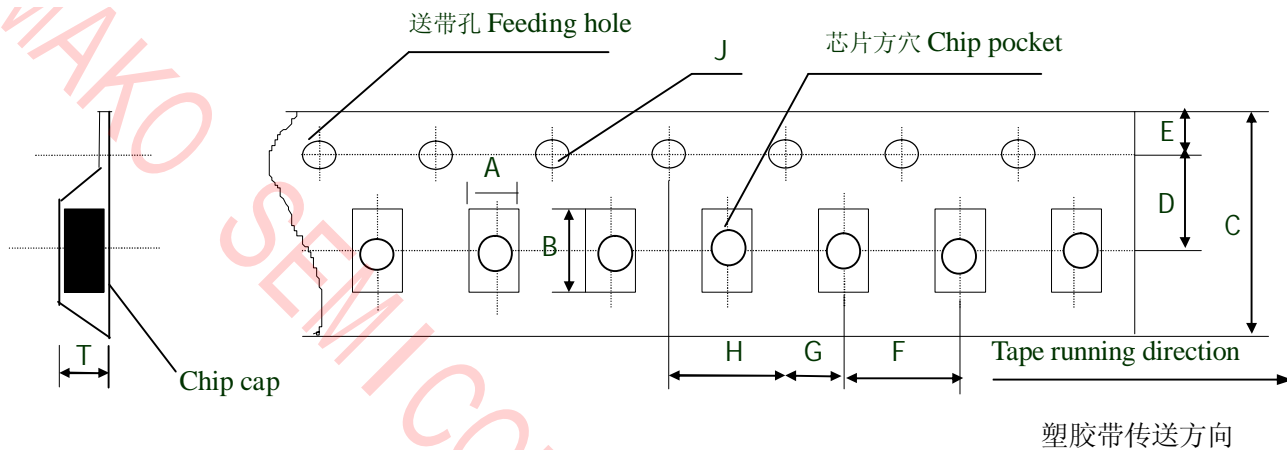

代号 Code 规格 Tape size	A	B	C	D*	E	F	G*	H	J	T
0805	1.55 ± 0.20	2.35 ± 0.20	8.00 ± 0.20	3.50 ± 0.05	1.75 ± 0.10	4.00 ± 0.10	2.00 ± 0.10	4.00 ± 0.10	1.50 -0/+0.10	1.50 Max
1206	1.95 ± 0.20	3.60 ± 0.20	8.00 ± 0.20	3.50 ± 0.05	1.75 ± 0.10	4.00 ± 0.10	2.00 ± 0.10	4.00 ± 0.1	1.50 -0/+0.10	1.85 Max
1210	2.70 ± 0.10	3.42 ± 0.10	8.00 ± 0.10	3.50 ± 0.05	1.75 ± 0.10	4.00 ± 0.10	2.00 ± 0.05	4.00 ± 0.10	1.55 -0/+0.10	3.2 Max
1808	2.20 ± 0.10	4.95 ± 0.10	12.00 ± 0.10	5.50 ± 0.05	1.75 ± 0.10	4.00 ± 0.10	2.00 ± 0.05	4.00 ± 0.10	1.50 -0/+0.10	3.0 Max
1812	3.66 ± 0.10	4.95 ± 0.10	12.00 ± 0.10	5.50 ± 0.05	1.75 ± 0.10	8.00 ± 0.10	2.00 ± 0.05	4.00 ± 0.10	1.55 -0/+0.10	4.0 Max

备注：*表示此处对尺寸的要求非常精确。

Note: The place with "*" means where needs exactly dimensions.

版本号	MK2008-001	
-----	------------	--

● 传送带的前后结构 Structure of leader part and end part of the carrier paper

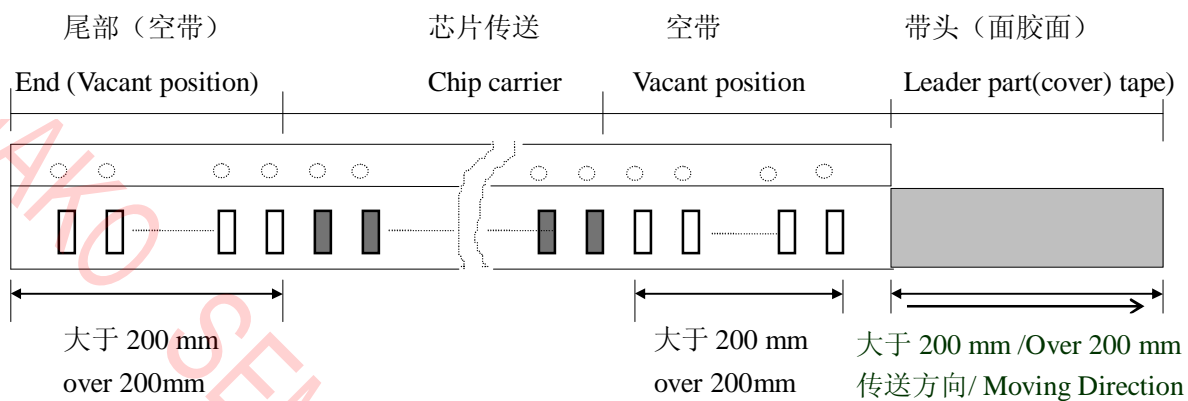

※ 卷盘尺寸 Reel Dimensions (unit: mm)

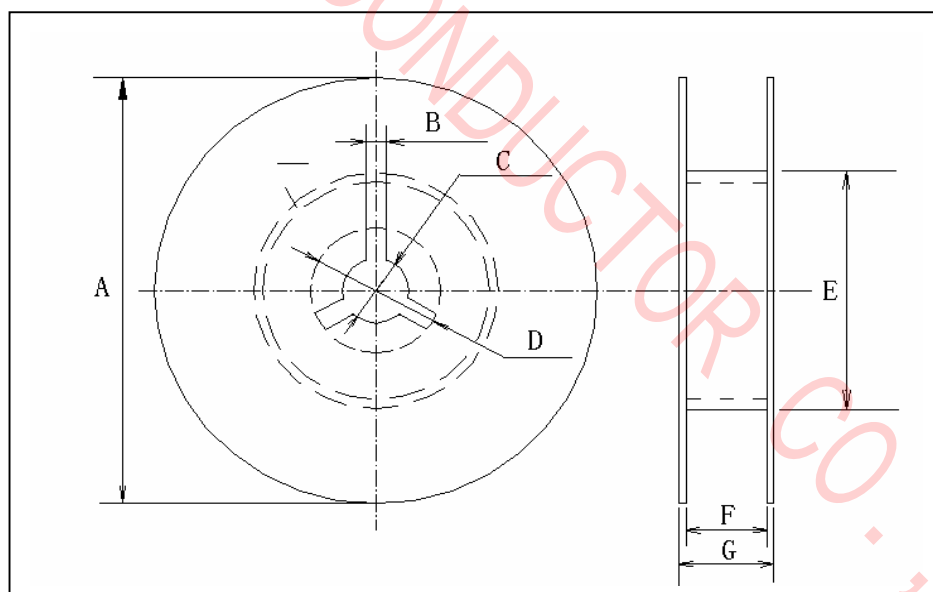

※ 尺寸代码 (CODE)

卷盘型号	A	B	C	D	E	F	G
7' REEL	$\phi 178 \pm 2.0$	3.0	$\phi 13 \pm 0.5$	$\phi 21 \pm 0.8$	$\phi 50$ 或更大 $\phi 50$ or more	100 ± 1.5	12max
13' REEL	$\phi 330 \pm 2.0$	3.0	$\phi 13 \pm 0.5$	$\phi 21 \pm 0.8$	$\phi 50$ 或更大 $\phi 50$ or more	100 ± 1.5	12max

● 关于卷带的说明 Taping specification

※面胶剥离强度 Top tape peeling strength

(a)纸带 Paper Taping

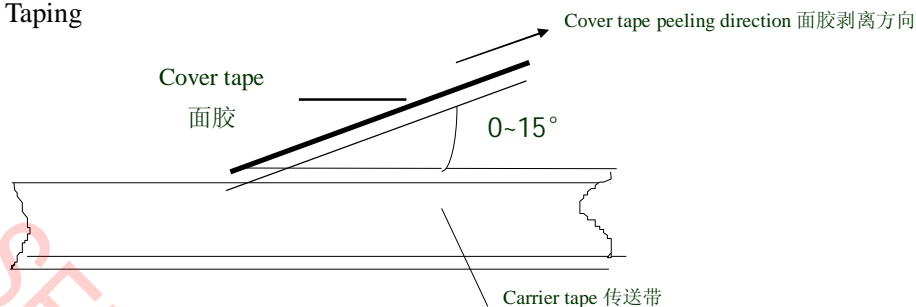

(b) 塑料胶盘 Embossed Taping

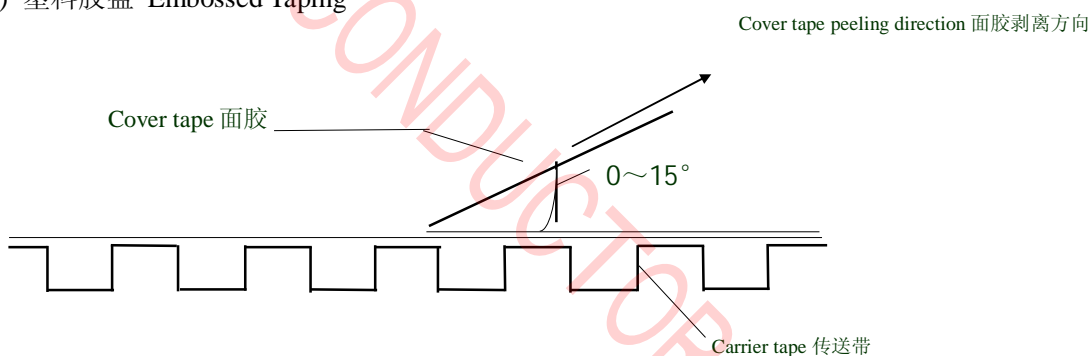

标准: 0.1N<剥离强度<0.7N

Standard: 0.1N < peeling strength < 0.7N

在剥离时, 纸带不能有纸碎, 也不能粘在底、面胶上。

No paper dirty remains on the scotch when peeling, and sticks to top and bottom tape.

※塑料盒散包装 Bulk Case Package

单位 (unit) :mm

Symbol	A	B	T	C	D	E
Dimension	6.80±0.10	8.80±1.00	12.00±0.10	15.00+0.10/-0	2.00+0/-0.10	4.70±0.10
Symbol	F	W	G	H	L	I
Dimension	31.50+0.20/-0	36.00+0/-0.20	19.00±0.35	7.00±0.35	110.00±0.70	5.00±0.35

版本号

MK2008-001

※包装数量 Packing Quantity

尺寸 (SIZE)	包装形式和数量 (PACKAGE STYLE & QUANTITY) unit: pcs			
	纸带卷盘 (PT)	胶带卷盘 (ET)	塑料盒散装 (BC)	一般散装 (BP)
0402	10000	-----	20000	5000
0603	4000	-----	15000	5000
0805	4000	2000	10000	5000
1206	4000	2000	5000	5000
1210	-----	2000	-----	2000
1808	-----	2000	-----	2000
1812	-----	2000	-----	2000
2225/2220	-----	-----	-----	500
3035	-----	-----	-----	-----

注意：包装的形式和数量可根据客户的要求来定。

Note: We can choose packing style and quantity can be according to the customer's requirement.

●外包装 Outer packing

小包装 The first package

Quantity: 5 reels (Max 25000pcs)

数量： 5 卷（25000pcs 最多）

大包装 The second package

Quantity: 12 cases (Max 300000pcs)

数量： 12 盒（最多 300000pcs）

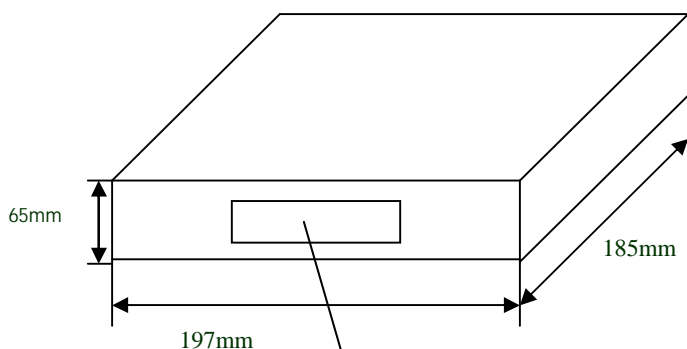

label 标签

PART No 型号规格
QUANTITY 数量
DATE 日期

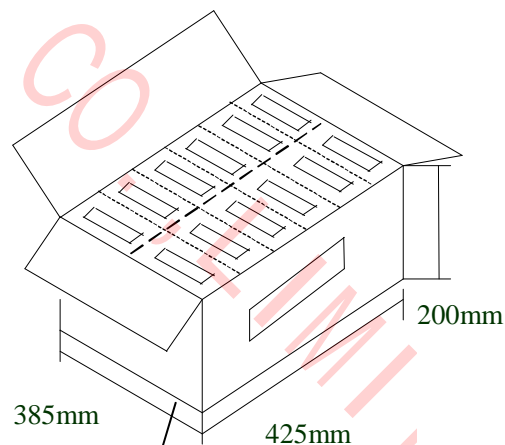

Label 标签

Production name 产品名称
Quantity 数量
Weight 重量

版本号

MK2008-001

十、储存方法 Storage Methods

确保芯片可焊性良好的贮存期限为 6 个月(在包装好已交付的情况下)。

The guaranteed period for solderability is 6 months (Under deliver package condition).

储存条件/Storage conditions:

储存温度/Temperature 5~40℃

储存相对湿度/Relative Humidity 20~70%

十一、使用前的注意事项 Precautions For Use

多层片式瓷介电容器(MLCC)在短路或开路的电路中都有可能失效,在超出本承认书或相关说明书中所述使用频率的恶劣工作环境,或外界机械力超压作用下,电容芯片都有可能着火、燃烧甚至爆炸,所以在使用的时候,首先应考虑按本承认书的有关说明来进行,如有不明之处,请联系我们技术部、品管部或生产部。

The Multi-layer Ceramic Capacitors (MLCC) may fail in a short circuit modern in an open circuit mode when subjected to severe conditions of electrical environment and / or mechanical stress beyond the specified “rating” and specified “conditions” in the specification, which will result in burn out, flaming or glowing in the worst case. Following “precautions for “safety” and Application Notes shall be taken in your major consideration. If you have a question about the precautions for handling, please contact our engineering section or factory.

1. 焊接的条件与相关图表 Soldering Profile

为避免因温度的突然变化而引起的芯片开裂或局部爆炸的现象发生,请按有关温度曲线图表来进行。(请参考附页中的图表)

To avoid the crack problem by sudden temperature change, follow the temperature profile in the adjacent graph (refer to the graph in the enclosure page).

2. 手工焊接 Manual Soldering

手工焊接很容易因为芯片局部受热不均而引起瓷体微裂或局部爆炸的现象,在焊接时,如果操作者不小心,会使烙铁头直接同电容芯片的瓷体部分接触,这样很容易使电容芯片因热冲击而受损或出现其他意外。因此,使用电烙铁手工焊接时应仔细操作,并对电烙铁的尖端的选择和尖端温度控制应多加小心。

Manual soldering can pose a great risk of creating thermal cracks in capacitors. The hot soldering iron tip comes into direct contact with the end terminations, and operator’s careless may cause the tip of the soldering iron to come into direct contact with the ceramic body of the capacitor. Therefore the soldering iron must be handled carefully, and pay much attention to the selection of the soldering iron tip and temperature contact of the tip.

3. 适量的焊料

焊料过多
Too much solder

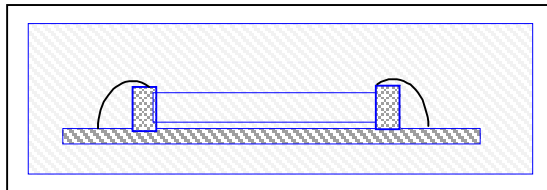

这样会因端头压力过大而
可能引起芯片受损
Cracks tend to occur due to large stress.

焊料太少
Not enough solder

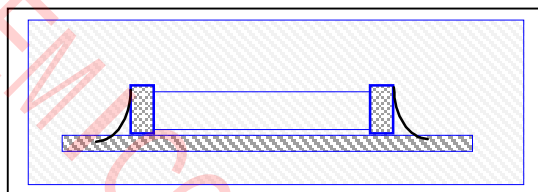

固定力量不足,可能会引起
电容芯片与线路接触不良
Weak holding force may cause bad
connection between the capacitor and
PCB.

十二、焊接温度曲线图 The temperature profile for soldering

回流焊接 (Re-flow soldering)

≥1210 规格推荐使用回流焊接

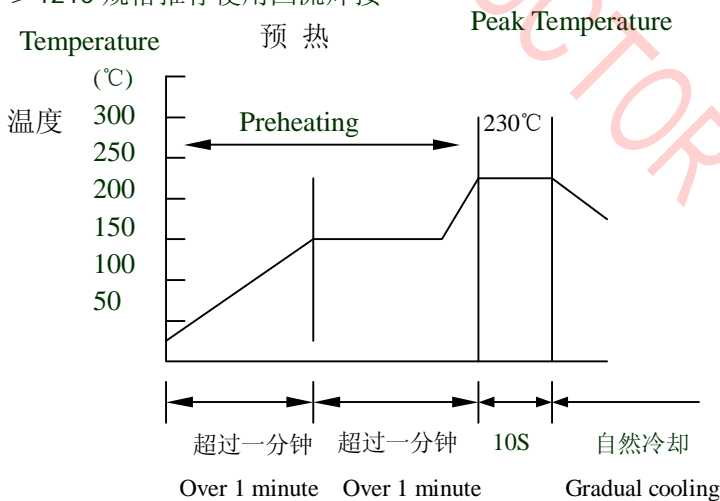

	Pb-Sn 焊接	无铅焊接
尖峰温度	230°C ~ 250°C	240°C ~ 260°C

波峰焊接 (Wave soldering)

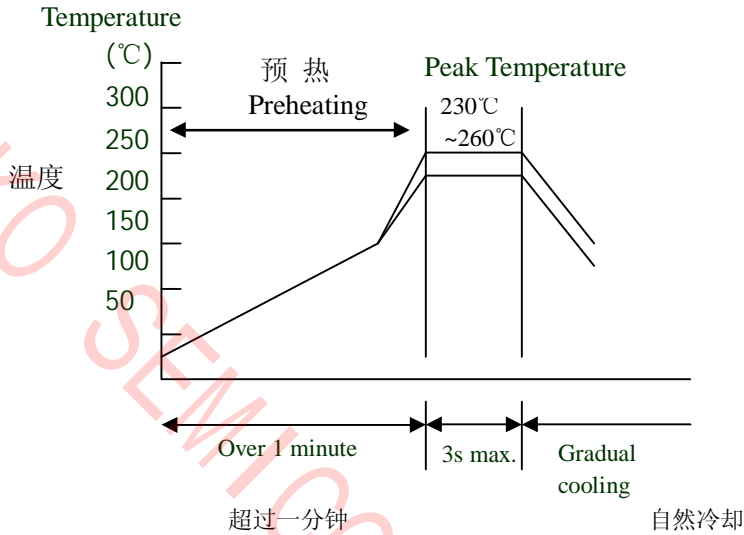

	Pb-Sn 焊接	无铅焊接
尖峰温度	230°C ~ 260°C	240°C ~ 270°C

在预热时，请将焊接温度与芯片表面温度之间的温差维持在 $T \leq 150^\circ\text{C}$ 。

手工焊接 (Hand soldering)

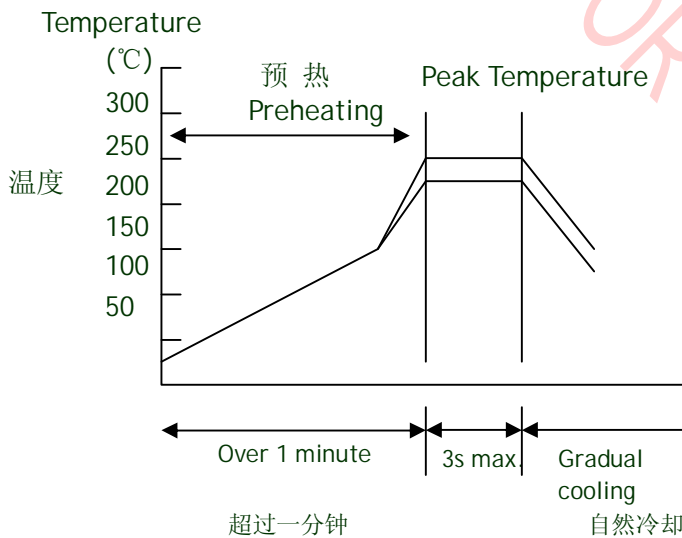

条件:

预热	烙铁头温度	烙铁功率	烙铁头直径	焊接时间	锡膏量	限制条件
$\Delta \leq 130^\circ\text{C}$	最高 300°C	最大 20W	建议 1mm	最长 5s	$\leq 1/2$ 芯片厚度	请勿使用烙铁头直接接触陶瓷元件

※以最新版本的内容为准

版本号	MK2008-001		
-----	------------	--	--

环保法规的声明:

1. 本公司生产的产品符合欧盟 ROHS 指令，外电极均不含铅，NPO 类陶瓷体含有少量铅，属于欧盟 ROHS 豁免项目。
2. 按中国 ROHS 指令，含有铅产品将会在产品说明书及承认书上声明，具体型号见下表:

环保标识	型 号	介质种类	容量范围
	0402	COG	0.1~470
	0603	COG	0.1~2200
	0805	COG	0.1~6800
	1206	COG	0.1~12000
	1210	COG	12~100000
	≥1808	COG	全部
	其余产品		