

Dual Channel 1A and 4A, 5.0kV_{RMS} Isolated Gate Driver

GENERAL DESCRIPTION

The SLMi823x isolated driver family is an isolated dual channel gate driver with different configurations. The SLMi8230/1/3/4 are configured as high-side/low-side drivers, while the SLMi8232/5 are configured as dual drivers. The peak source output current of SLMi8230/1/2 is 1.0A and the peak source output current of SLMi8233/4/5 is 4.0A. Programmable dead time (DT) feature is available in SLMi8230/1/3/4. Pulling high the DIS pin shuts down both outputs simultaneously, and allows for normal operation when the DIS pin is open or pulled low. As a fail-safe measure, primary-side logic failures force both outputs low.

The VDDA and VDDB supply voltage are up to 40 V. A wide input VDDI range from 3 V to 18 V makes the driver suitable for interfacing with both analog and digital controllers. All the supply voltage pins have under voltage lock-out (UVLO) protection.

The SLMi823x has 5.0kV_{RMS} isolation in SOP16W package per UL1577.

High CMTI, low propagation delay, small size and flexible configuration make the SLMi823x family is suitable for a wide range of isolated MOSFET/IGBT and SiC or GaN FET gate drive applications.

FEATURE

- 1.0A or 4.0A peak source current
- 40ns (Typ.) propagation delay
- 18ns (Max.) pulse width distortion
- 18ns (Max.) delay matching
- 100kV/us (Min.) common mode transient immunity (CMTI)
- Wide input voltage: 3V to 18V
- Up to 40V driver output voltage
- 5V reverse polarity voltage handling capability on input stage
- 1500V functional isolation between two drivers
- Operating temperature: -40°C to +125°C
- Safety certifications:
 - 5kVRMS isolation for 1 minute per UL 1577 with SOP16W package
 - CQC certification per GB4943.1-2011
 - DIN V VDE 0884-11 (Planned)

APPLICATION

- AC/DC or DC/DC power supplies in server, telecom and industry
- DC/AC solar inverters
- EV battery charging

APPLICATION CIRCUIT

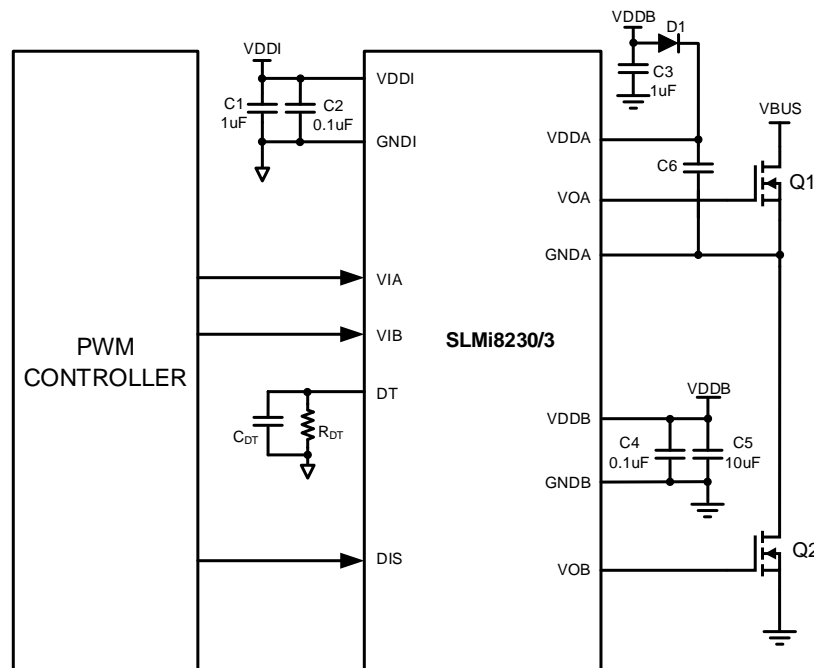

Figure 1. SLMi8230/3 Application Circuit

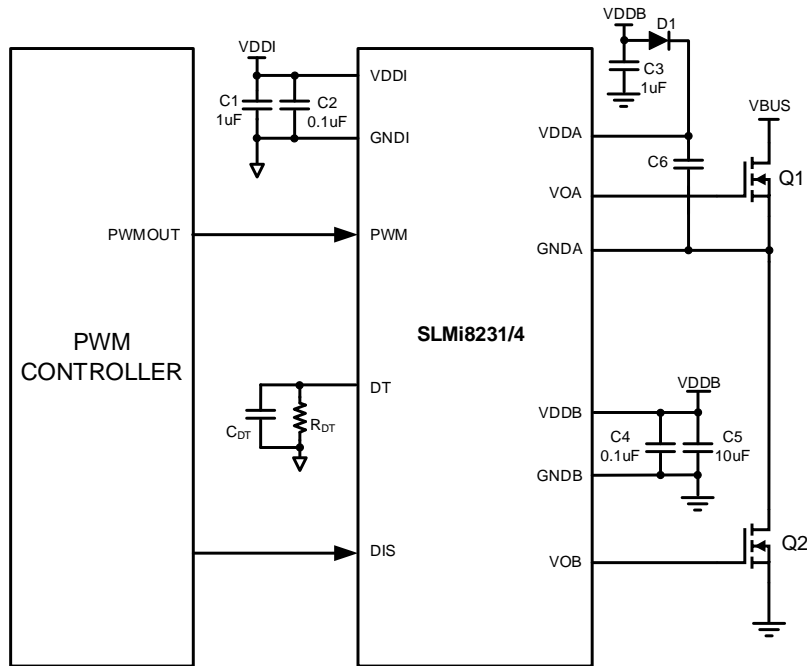

Figure 2. SLMi8231/4 Application Circuit

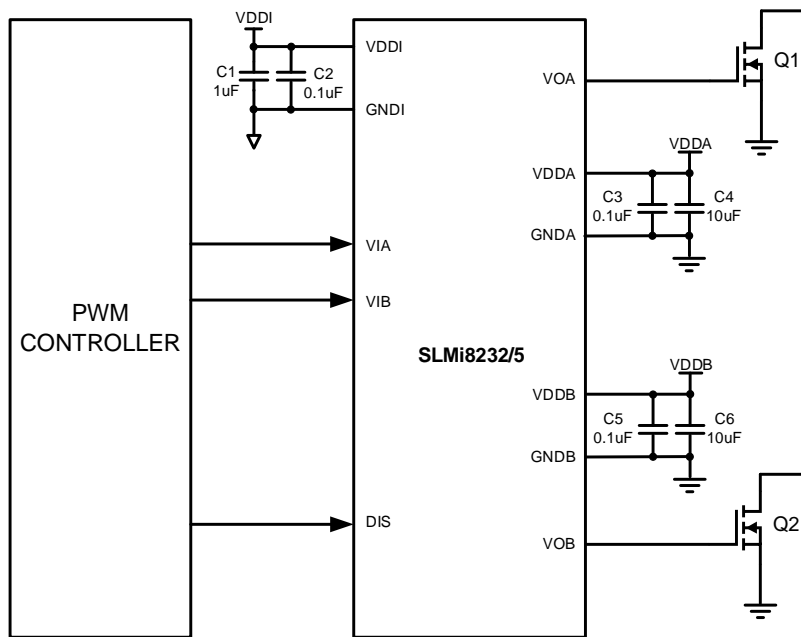

Figure 3. SLMi8232/5 Application Circuit

Table of Contents

General Description	1
Feature.....	1
Application	1
Application Circuit	1
PIN Configuration	4
PIN Description	5
Functional Block Diagram	7
Ordering Information	8
Family Overview	8
Absolute Maximum Ratings ¹	9
Recommended Operation Conditions ¹	9
ESD Ratings	9
Thermal Information.....	10
Package Specifications.....	11
Insulation Specifications	11
Safety Related Certifications	12
Safety LimitING Values.....	12
Electrical Characteristics (DC).....	13
Switching Characteristics (AC)	14
Parameter Measurement Information	15
Propagation Delay and Pulse Width Distortion	15
Rise and Fall Time Testing.....	15
CMTI Testing	15
Feature Description	16
Under Voltage Lockout.....	16
Disable Input Function.....	16
Control Input and Output Logic	16
Dead-time Program	17
Application Information	19
Layout	20
Package Case Outlines	21
Reflow Profile Guidance	22
Revision History.....	23

PIN CONFIGURATION

Part Number	Pin Configuration (Top View)
SLMi8230/3	
SLMi8231/4	
SLMi8232/5	

PIN DESCRIPTION
Table 1. SLMi8230/3 Pin Description

No.	Pin	Description
1	VIA	Input of driver A. The output of driver A is in phase with the input. This pin is pulled low internally if left open. Recommend to connect this pin to ground if not used for better noise immunity.
2	VIB	Input of driver B. The output of driver B is in phase with the input. This pin is pulled low internally if left open. Recommend to connect this pin to ground if not used for better noise immunity.
3	VDDI	Input power supply. A local low ESR and ESL capacitor should be connected between VDDI and GNDI.
4	GNDI	Input power ground.
5	DIS	Device disable input. When DIS pin is high, both driver is disabled and driver output is low. When DIS pin is low, it allows the device to perform in normal operation.
6	DT	Dead time programming input. Connect a resistor between DT and GNDI to program the dead time. A bypassing capacitor, 2.2nF or greater, is recommended to be put between DT and GNDI to achieve better noise immunity.
7	NC	No connection
8	VDDI	Input power supply. This pin is internally connected to pin3.
9	GNDB	Power ground of driver B.
10	VOB	Output of driver B.
11	VDDB	Power supply of driver B. A local low ESR and ESL capacitor should be connected between VDDB and GNDB.
12	NC	No connection
13	NC	No connection
14	GNDA	Power ground of driver A.
15	VOA	Output of driver A.
16	VDDA	Power supply of driver A. A local low ESR and ESL capacitor should be connected between VDDA and GNDA.

Table 2. SLMi8231/4 Pin Description

No.	Pin	Description
1	PWM	PWM input. The output of driver A is in phase with PWM input and the output of driver B is out of phase with PWM input.
2	NC	No connection
3	VDDI	Input power supply. A local low ESR and ESL capacitor should be connected between VDDI and GNDI.
4	GNDI	Input power ground.
5	DIS	Device disable input. When DIS pin is high, both driver is disabled and driver output is low. When DIS pin is low, it allows the device to perform in normal operation.
6	DT	Dead time programming input. Connect a resistor between DT and GNDI to program the dead time. A bypassing capacitor, 2.2nF or greater, is recommended to be put between DT and GNDI to achieve better noise immunity.

No.	Pin	Description
7	NC	No connection
8	VDDI	Input power supply. This pin is internally connected to pin3.
9	GNDB	Power ground of driver B.
10	VOB	Output of driver B.
11	VDDB	Power supply of driver B. A local low ESR and ESL capacitor should be connected between VDDB and GNDB.
12	NC	No connection
13	NC	No connection
14	GNDA	Power ground of driver A.
15	VOA	Output of driver A.
16	VDDA	Power supply of driver A. A local low ESR and ESL capacitor should be connected between VDDA and GNDA.

Table 3. SLMi8232/5 Pin Description

No.	Pin	Description
1	VIA	Input of driver A. The output of driver A is in phase with the input. This pin is pulled low internally if left open. Recommend to connect this pin to ground if not used for better noise immunity.
2	VIB	Input of driver B. The output of driver B is in phase with the input. This pin is pulled low internally if left open. Recommend to connect this pin to ground if not used for better noise immunity.
3	VDDI	Input power supply. A local low ESR and ESL capacitor should be connected between VDDI and GNDI.
4	GNDI	Input power ground.
5	DIS	Device disable input. When DIS pin is high, both driver is disabled and driver output is low. When DIS pin is low, it allows the device to perform in normal operation.
6	NC	No connection
7	NC	No connection
8	VDDI	Input power supply. This pin is internally connected to pin3.
9	GNDB	Power ground of driver B.
10	VOB	Output of driver B.
11	VDDB	Power supply of driver B. A local low ESR and ESL capacitor should be connected between VDDB and GNDB.
12	NC	No connection
13	NC	No connection
14	GNDA	Power ground of driver A.
15	VOA	Output of driver A.
16	VDDA	Power supply of driver A. A local low ESR and ESL capacitor should be connected between VDDA and GNDA.

FUNCTIONAL BLOCK DIAGRAM

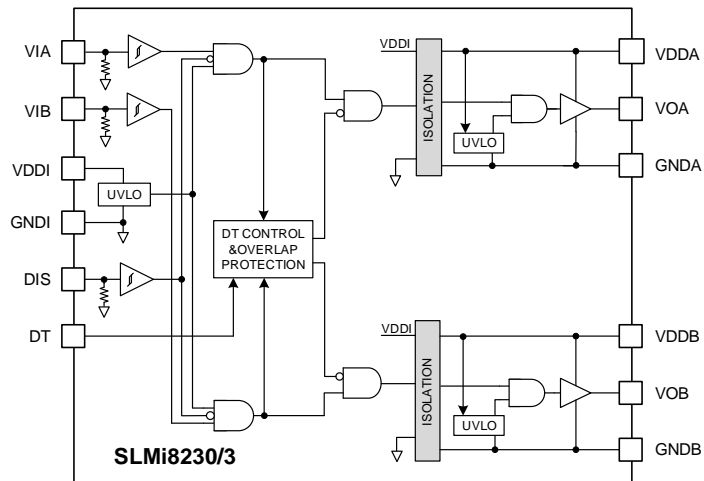

Figure 4. SLMi8230/3 Functional Block Diagram

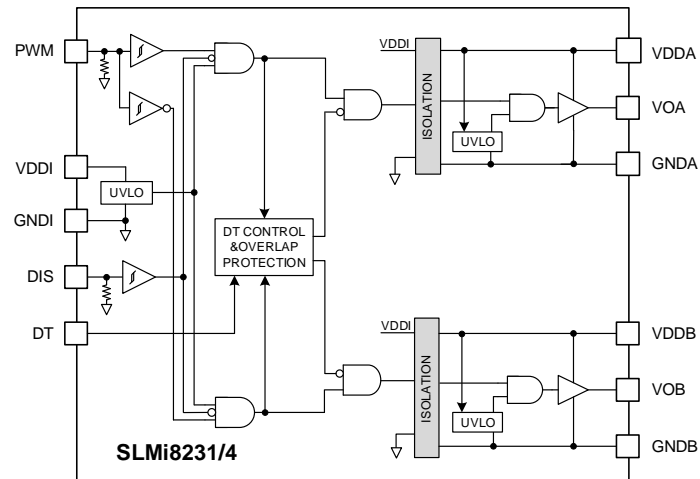

Figure 5. SLMi8231/4 Functional Block Diagram

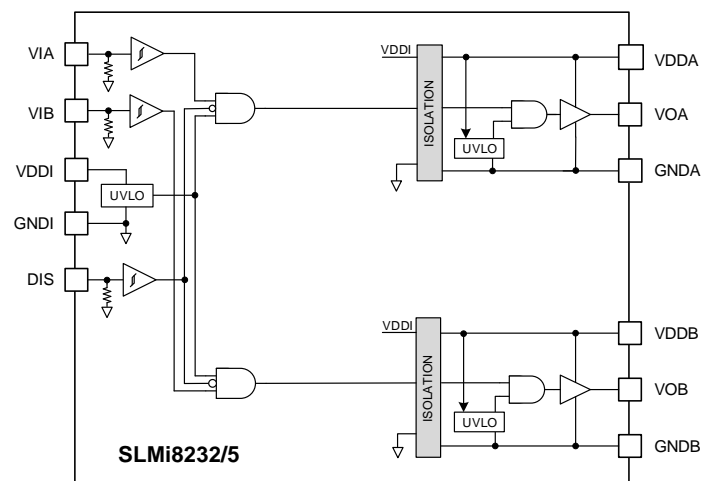

Figure 6. SLMi8232/5 Functional Block Diagram

ORDERING INFORMATION

Order Part No.	Package	QTY
SLMi8230BDCG-DG	SOP16W, Pb-Free	1500/Reel
SLMi8230DDCG-DG	SOP16W, Pb-Free	1500/Reel
SLMi8231BDCG-DG	SOP16W, Pb-Free	1500/Reel
SLMi8231DDCG-DG	SOP16W, Pb-Free	1500/Reel
SLMi8232BDCG-DG	SOP16W, Pb-Free	1500/Reel
SLMi8232DDCG-DG	SOP16W, Pb-Free	1500/Reel
SLMi8233BDCG-DG	SOP16W, Pb-Free	1500/Reel
SLMi8233DDCG-DG	SOP16W, Pb-Free	1500/Reel
SLMi8234BDCG-DG	SOP16W, Pb-Free	1500/Reel
SLMi8234DDCG-DG	SOP16W, Pb-Free	1500/Reel
SLMi8235BDCG-DG	SOP16W, Pb-Free	1500/Reel
SLMi8235DDCG-DG	SOP16W, Pb-Free	1500/Reel

FAMILY OVERVIEW

Part Number	Input Configuration	Output Configuration	Programmable Dead Time	Overlap Protection	Peak Output Current	UVLO
SLMi8230BDCG-DG	VIA, VIB	HS/LS	Yes	Yes	1.0 A	8.5V/7.5V
SLMi8230DDCG-DG	VIA, VIB	HS/LS	Yes	Yes	1.0 A	12.5V/11.5V
SLMi8231BDCG-DG	PWM	HS/LS	Yes	Yes	1.0 A	8.5V/7.5V
SLMi8231DDCG-DG	PWM	HS/LS	Yes	Yes	1.0 A	12.5V/11.5V
SLMi8232BDCG-DG	VIA, VIB	Dual Driver	No	No	1.0 A	8.5V/7.5V
SLMi8232DDCG-DG	VIA, VIB	Dual Driver	No	No	1.0 A	12.5V/11.5V
SLMi8233BDCG-DG	VIA, VIB	HS/LS	Yes	Yes	4.0 A	8.5V/7.5V
SLMi8233DDCG-DG	VIA, VIB	HS/LS	Yes	Yes	4.0 A	12.5V/11.5V
SLMi8234BDCG-DG	PWM	HS/LS	Yes	Yes	4.0 A	8.5V/7.5V
SLMi8234DDCG-DG	PWM	HS/LS	Yes	Yes	4.0 A	12.5V/11.5V
SLMi8235BDCG-DG	VIA, VIB	Dual Driver	No	No	4.0 A	8.5V/7.5V
SLMi8235DDCG-DG	VIA, VIB	Dual Driver	No	No	4.0 A	12.5V/11.5V

ABSOLUTE MAXIMUM RATINGS¹

Symbol	Definition	Min	Max	Unit
V _{DDI}	Input Power Supply Voltage	-0.3	20	V
V _{IA} , V _{IB} , V _{DIS} , V _{PWM}	Input Signal Voltage	-7	20	V
V _{DDA} , V _{DDB}	Driver Power Supply	-0.3	45	V
V _{OUTA} , V _{OUTB}	Driver Output Voltage	-0.3	V _{DDA} +0.3, V _{DDB} +0.3	V
	Driver Output Voltage, Transient for 200ns ²	-3	V _{DDA} +0.3, V _{DDB} +0.3	V
	Driver Output Voltage, Transient for 50ns ²	-6	V _{DDA} +0.3, V _{DDB} +0.3	V
V _{ch2ch}	Channel to Channel Voltage		1500	V
T _J	Junction Temperature	-40	150	°C
T _S	Storage Temperature	-65	150	°C

RECOMMENDED OPERATION CONDITIONS¹

Symbol	Definition	Min	Max	Unit
V _{DDI}	Input Power Supply Voltage	3	18	V
V _{IA} , V _{IB} , V _{DIS} , V _{PWM}	Input Signal Voltage	-5	18	V
V _{DDA} , V _{DDB}	Driver Power Supply (8.5V UVLO Version)	9	40	V
V _{DDA} , V _{DDB}	Power Supply for Driver (12.5V UVLO Version)	13.5	40	V
T _J	Junction Temperature	-40	150	°C
T _A	Storage Temperature	-40	125	°C

ESD RATINGS

Symbol	Definition	Value	Units
V _{ESD}	HBM	±4000	V
	CDM	±2000	

Note 1: V_{DDI}, V_{IA}, V_{IB}, V_{DIS}, V_{PWM} are reference to GNDI; V_{DDA}, V_{OUTA} are referenced to GNDA; V_{DDB}, V_{OUTB} are referenced to GNDB;

Note 2: Values are verified by characterization on bench

THERMAL INFORMATION

Symbol	Definition	Value	Unit
$R_{\theta JA}$	Junction to ambient thermal resistance	100	°C/W
$R_{\theta JC(TOP)}$	Junction to case (top) thermal resistance	40	°C/W

PACKAGE SPECIFICATIONS

Symbol	Definition	Min.	Typ.	Max.	Units
R _{IO}	Resistance (Input Side to Output Side)		10 ¹²		Ω
C _{IO}	Capacitance (Input Side to Output Side)		1.8		pF

INSULATION SPECIFICATIONS

Symbol	Definition	Test Condition	Value	Units
CLR	External clearance	Shortest terminal to terminal distance through air	8.0	mm
CPG	External creepage	Shortest terminal to terminal distance across the package surface	8.0	mm
DTI	Distance through the insulation	Minimum internal gap	>16	um
CTI	Comparative tracking index	DIN EN 60112 (VDE 0303-11), IEC 60112	>600	V
	Material Group		I	
	Overvoltage category	Rated mains voltages ≤150Vrms	I-IV	
		Rated mains voltages ≤300Vrms	I-IV	
		Rated mains voltages ≤600Vrms	I-IV	
		Rated mains voltages ≤1000Vrms	I-III	
DIN V VDE 0884-11⁽¹⁾				
V _{IORM}	Maximum repetitive peak isolation voltage		1414	V _{PK}
V _{IOWM}	Maximum isolation working voltage		1000	V _{RMS}
V _{IOTM}	Maximum transient isolation voltage	60s	8000	V _{PK}
V _{IOSM}	Maximum surge isolation voltage	Test method per IEC62368, 1.2/50us waveform, V _{TEST} =1.6 x V _{IOSM}	6250	V _{PK}
q _{pd}	Apparent charge	Method b2: V _{pd(m)} =1.875 x V _{IORM} , t _m =1 s	≤5	pC
	Climatic Category		40/125/21	
	Pollution Degree		2	
UL1577				
V _{ISO}	Withstand Isolation Voltage	V _{TEST} =V _{ISO} , t=60s (qualification), V _{TEST} =1.2 x V _{ISO} , t=1s (100% production)	5000	V _{RMS}

Note 1: Certification planned

SAFETY RELATED CERTIFICATIONS

VDE	UL	CQC
DIN V VDE 0884011-11: 2017-01	UL 1577 component recognition program	Certified according to GB4943.1-2011
Reinforced Insulation	Single protection, 5000 V _{RMS}	Reinforced insulation, Altitude ≤ 5000m, Tropical climate, 400 V _{RMS} maximum working voltage
Certification Pending	File number: E521801	File number: CQC21001324484

SAFETY LIMITING VALUES

Symbol	Parameter	Condition	Side	Value	Unit
I _s	Safety output current	V _{DDA} =V _{DDDB} =16V, C _{LOAD} =1nF, 2MHz PWM, 50% duty, R _{θJA} =100°C/W, T _J =150°C, T _A =25°C	Driver A and Driver B	73	mA
P _s	Safety input, output, or total power	V _{DDA} =V _{DDDB} =16V, C _{LOAD} =1nF, V _{DDI} =12V, 2MHz PWM, 50% duty, R _{θJA} =100°C/W, T _J =150°C, T _A =25°C	Input	36	mW
			Driver A	584	
			Driver B	584	
			Total	1204	
T _s	Maximum safety temperature			150	°C

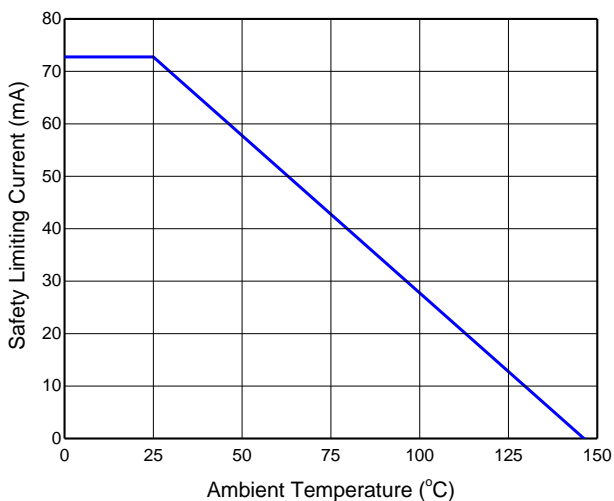

Figure 7. Thermal Derating Curve for Limiting Current per VDE (Current in VDDA and VDDB)

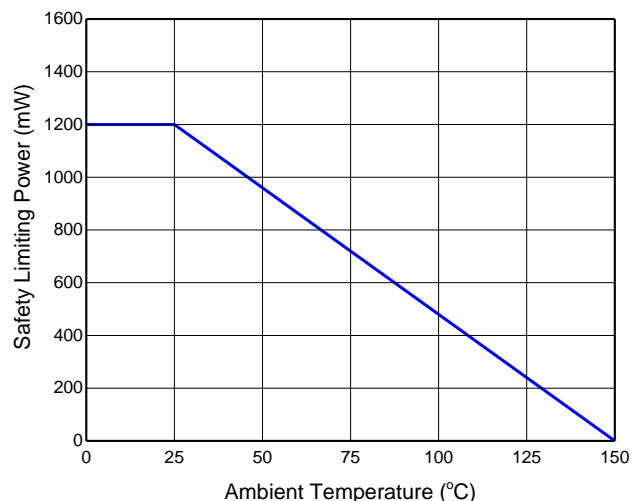

Figure 8. Thermal Derating Curve for Limiting Power per VDE

ELECTRICAL CHARACTERISTICS (DC)

$V_{DDI} = 5\text{ V}$, $0.1\mu\text{F}$ capacitor from V_{DDI} to $GNDI$, $V_{DDA} = V_{DDB} = 15\text{V}$, $1\mu\text{F}$ capacitor from V_{DDA} and V_{DDB} to $GNDA$ and $GND B$, $T_A = -40^\circ\text{C}$ to $+125^\circ\text{C}$, unless otherwise specified.

Symbol	Parameter	Condition	Min	Typ	Max	Unit
Input Power Supply						
V_{DDI}	Input Supply Voltage		3		18	V
$V_{UVLO_VDDI_R}$	VDDI UVLO Rising		2.55	2.7	2.85	V
$V_{UVLO_VDDI_F}$	VDDI UVLO Falling		2.35	2.5	2.65	V
V_{UVLO_HYS}	VDDI UVLO Hysteresis			0.2		V
I_{VDDI}	Quiescent Current	$V_{IA} = 0\text{V}$, $V_{IB} = 0\text{V}$	1.4	2	2.6	mA
	Operation Current	$f_{sw} = 100\text{kHz}$, (50% Duty Cycle), both channels		3.3		mA
Logic Interface						
V_{IH}	High Level Input Threshold Voltage at VIA, VIB, DIS and PWM		2			V
V_{IL}	Low Level Input Threshold Voltage at VIA, VIB, DIS and PWM				0.8	V
R_{PD}	Pull down Resistance on VIA, VIB, DIS and PWM		126	180	235	k Ω
Driver Power Supply						
$V_{UVLO_VDDA_R}$, $V_{UVLO_VDD B_R}$	VDDA, VDD B UVLO Rising	8.5V UVLO Version	8	8.5	9	V
		12.5V UVLO Version	11.5	12.5	13.5	V
$V_{UVLO_VDDA_F}$, $V_{UVLO_VDD B_F}$	VDDA, VDD B UVLO Falling	8.5V UVLO Version	7	7.5	8	V
		12.5V UVLO Version	10.5	11.5	12.5	V
$V_{UVLO_VDDA_HYS}$, $V_{UVLO_VDD B_HYS}$	VDDA, VDD B UVLO Hysteresis	8.5V UVLO Version		1		V
		12.5V UVLO Version		1		V
I_{VDDA} , $I_{VDD B}$	VDDA/B Quiescent Current, per Channel	$V_{IA} = 0\text{V}$, $V_{IB} = 0\text{V}$	0.8	1.5	2.6	mA
OUTPUT (SLMi8230/1/2)						
I_{OH}	Peak Source Current			1		A
I_{OL}	Peak Sink Current			1.5		A
V_{OH}	High Level Output Voltage	$I_o = -10\text{mA}$		70	120	mV
V_{OL}	Low Level Output Voltage	$I_o = 10\text{mA}$		30	65	mV
OUTPUT (SLMi8233/4/5)						
I_{OH}	Peak Source Current			4		A
I_{OL}	Peak Sink Current			7		A

Symbol	Parameter	Condition	Min	Typ	Max	Unit
V _{OH}	High Level Output Voltage	I _o =-10mA		12	22	mV
V _{OL}	Low Level Output Voltage	I _o =10mA		6.2	11	mV
Dead Time						
R _{DT}	Resistance range on DT		5		220	kΩ
t _{DT}	Dead time	R _{DT} =20kΩ	160	200	240	ns
C _{DT}	Capacitance of C _{DT}				10	nF

SWITCHING CHARACTERISTICS (AC)

V_{DDI} = 5 V, 0.1μF capacitor from V_{DDI} to G_{NDI}, V_{VDDA} = V_{VDDB} = 15V, 1μF capacitor from V_{VDDA} and V_{VDDB} to G_{ND A} and G_{ND B}, T_A = -40°C to +125°C, unless otherwise specified.

Symbol	Parameter	Condition	Min	Typ	Max	Unit
Switching Characteristics						
t _{PLH}	Propagation Delay, Low to High	C _{LOAD} =1nF, f _{sw} =1kHz, (50% Duty Cycle)		40	60	ns
t _{PHL}	Propagation Delay, High to Low			40	60	ns
t _r	Turn on Rise Time			6	15	ns
t _f	Turn off Fall Time			4	10	ns
t _{PWD}	Pulse Width Distortion				18	ns
t _{DM}	Propagation Delay Matching between OUTA and OUTB				18	ns
t _{UVLO_REC_VDDI}	V _{DDI} UVLO Recovery Delay			15		μs
t _{UVLO_REC_VDDA(B)}	V _{VDDA} , V _{VDDB} UVLO Recovery Delay			18		μs
CMTI _H	High Level Static Common Mode Transient Immunity	V _{CM} =1000V, T _A =25°C	100			kV/μs
CMTI _L	Low Level Static Common Mode Transient Immunity	V _{CM} =1000V, T _A =25°C	100			kV/μs

PARAMETER MEASUREMENT INFORMATION

Propagation Delay and Pulse Width Distortion

Figure 9 shows the timing diagram of the propagation delay t_{PDLH} and t_{PDHL} , pulse distortion t_{PWD} and delay matching t_{DM} from the input V_{IA} and V_{IB} . Short the DT pin to VDDI to disable the dead time function.

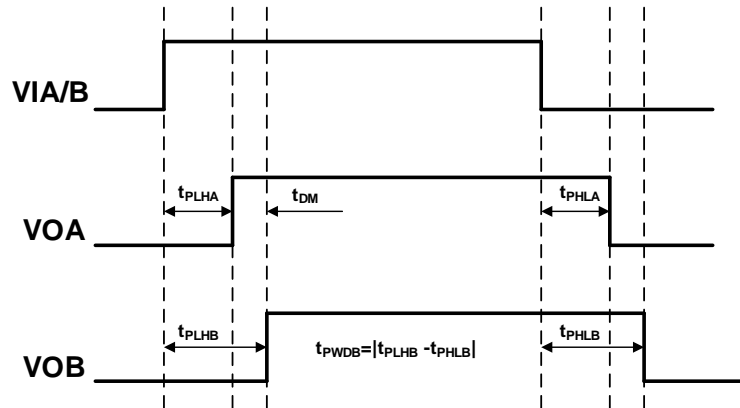

Figure 9. Propagation Delay and Pulse Width Distortion

Rise and Fall Time Testing

Figure 10 shows the criteria for measuring rise time (t_r) and fall time (t_f).

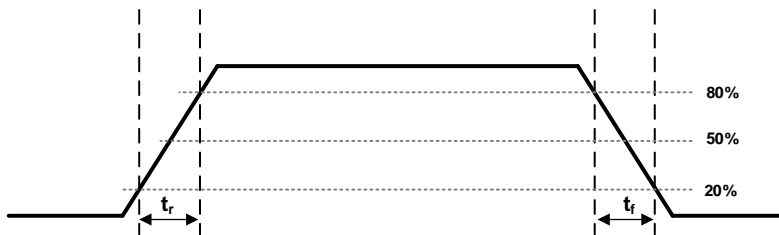

Figure 10. Turn On Rise Time and Turn Off Fall Time

CMTI Testing

Figure 11 is the simplified diagram of the CMTI testing. Common mode voltage is set to 1000V.

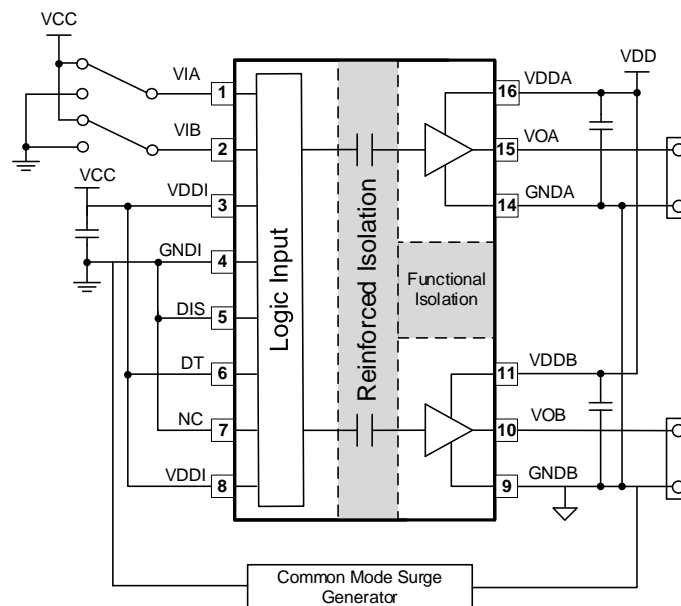

Figure 11. CMTI Test Circuit

FEATURE DESCRIPTION

SLMi823x is a flexible dual channel isolated gate driver that can drive IGBTs and MOSFETs. It has 1.0A or 4.0A peak output current capability with maximum output driver supply voltage of 40V. SLMi823x has many features that allow it to integrate well with control circuitry and protect the gates it drives such as: resistor programmable dead time control, an DIS pin, and under voltage lock out (UVLO) for both input and output voltages.

Under Voltage Lockout

The SLMi823x has under voltage lock out (UVLO) protection feature on each driver power supply voltage between the VDDA (VDDDB) and GNDA (GNDB) pins. When the VDDx voltage is lower than $V_{UVLO_VDDX_R}$, during device start up or lower than $V_{UVLO_VDDX_F}$, after start up, the VDDA (VDDDB) UVLO feature holds the driver output low, regardless of the status of the input pins. A hysteresis on the UVLO feature prevents glitch when there is noise from the power supply.

The SLMi823x also monitors the input power supply and there is an internal under voltage lock out protection feature on the VDDI. The driver outputs (VOA and VOB) are hold low when the voltage on the VDDI is lower than $V_{UVLO_VDDI_R}$ during start up or lower than $V_{UVLO_VDDI_F}$ after start up. There is a hysteresis on the VDDI UVLO feature to prevent glitch due the noise on the VDDI power supply.

Disable Input Function

When the DIS is pulled high, the VOA and VOB are pulled low regardless of the states of VIA and VIB. When the DIS pin is pulled low, the VOA and VOB are allowed for normal operation and controlled by the VIA and VIB.

The DIS input has no effect if VDDI is below its UVLO threshold and VOA, VOB remain low. There is an internal pull down resistor on the DIS pin.

Control Input and Output Logic

The VIA and VIB input controls the corresponding output channel, VOA and VOB. A logic high signal on VIA (VIB) causes the output of VOA (VOB) to go high. And a logic low on VIA (VIB) causes the output of VOA (VOB) to go low.

For PWM input versions (SLMi8231/4), when the PWM input is high, the VOA is high and VOB is low. And when the PWM input is low, the VOA is low and VOB is high.

The Table 4 and Table 5 show the relationship between VIA, VIB, PWM, DIS, UVLO and Output of VOA and VOB.

Table 4. Relationship between Input and Output with VIA, VIB input (SLMi8230/2/3/5)

VIA	VIB	DIS	VDDI UVLO	VDDA UVLO	VDDB UVLO	VOA	VOB	Note
H	L	L	No	No	No	H	L	
L	H	L	No	No	No	L	H	
L	L	L	No	No	No	L	L	
H	H	L	No	No	No	H	H	SLMi8232/5
						L	L	SLMi8230/3
X	X	H	No	No	No	L	L	Device disabled
X	X	X	Yes	No	No	L	L	VDDI UVLO active
H	X	L	No	No	Yes	H	L	VDDB UVLO active
					Yes	L	L	
X	H	L	No	Yes	No	L	H	VDDA UVLO active
				No	No	L	L	

Table 5. Relationship between Input and Output with PWM input (SLMi8231/4)

PWM	DIS	VDDI UVLO	VDDA UVLO	VDDB UVLO	VOA	VOB	Note
H	L	No	No	No	H	L	
L	L	No	No	No	L	H	
X	H	No	No	No	L	L	Device disabled
X	X	Yes	No	No	L	L	VDDI UVLO active
H	L	No	No	Yes	H	L	VDDB UVLO active
L	L	No	No	Yes	L	L	VDDB UVLO active
H	L	No	Yes	No	L	L	VDDA UVLO active
L	L	No	Yes	No	L	H	VDDA UVLO active

Dead-time Program

For the high side/low side configuration driver, there is a dead-time between VOA and VOB. The dead-time delay (t_{DT}) is programmed by a resistor (R_{DT}) connected from the DT input to ground and it can be calculated with below equation.

$$t_{DT}[\text{ns}] \approx 10 \times R_{DT}[\text{k}\Omega]$$

Here, t_{DT} is the dead-time delay, R_{DT} is the resistance value between DT and ground.

The DT pin can be connected to VDDI or left floating to provide a nominal dead time at approximately 400 ps.

A bypassing capacitor, 2.2nF or greater, is recommended to be put between DT and GNDI to achieve better noise immunity.

The Figure 12 shows the input and output logic with dead-time in different condition.

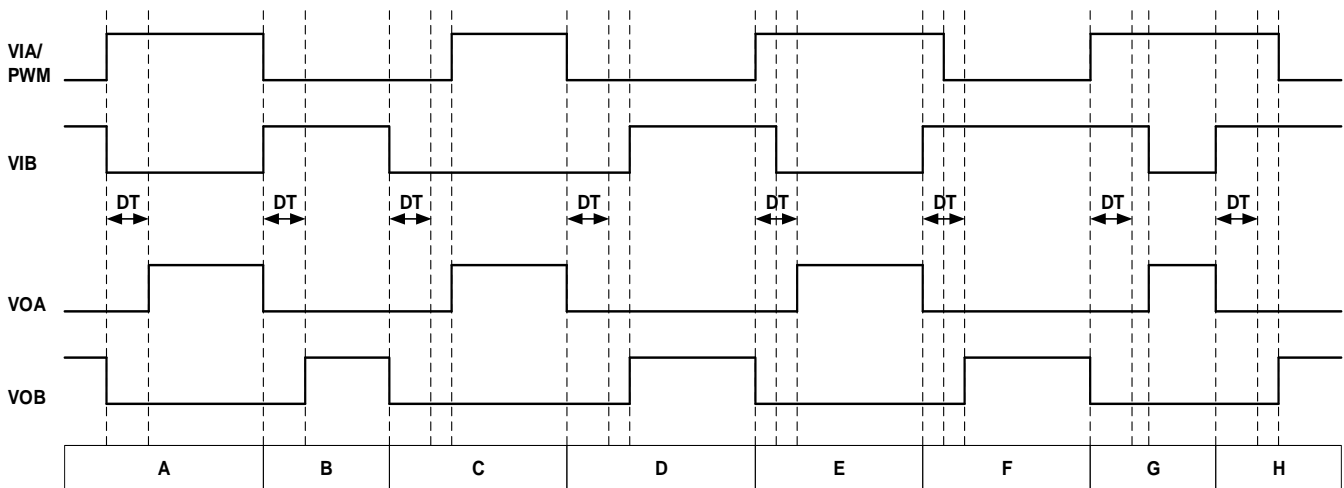

Figure 12. Input and output logic with dead-time

Condition A: VIA goes high and VIB goes low. VOB goes low immediately and VOA goes high after the programmed dead-time.

Condition B: VIA goes low and VIB goes high. VOA goes low immediately and VOB goes high after the programmed dead-time.

Condition C: VIB goes low and VIA still low. VOB goes low immediately. Since the VIA input dead-time is longer than the programmed dead-time, the VOA goes high immediately when the VIA input goes high.

Condition D: VIA goes low and VIB still low. VOA goes low immediately. Since the VIB input dead-time is longer than the programmed dead-time, the VOB goes high immediately when the VIB input goes high.

Condition E: VIA goes high while VIB and VOB are still high, the overlap time is shorter than the programmed dead-time. To avoid overshoot, VOB goes low immediately when the VIA goes high. The VOA goes high after the programmed dead-time.

Condition F: VIB goes high while VIA and VOA are still high, the overlap time is shorter than the programmed dead-time. To avoid overshoot, VOA goes low immediately when the VIB goes high. The VOB goes high after the programmed dead-time.

Condition G: VIA goes high while VIB and VOB are still high, the overlap time is longer than the programmed dead-time. To avoid overshoot, VOB goes low immediately when the VIA goes high. Since the overlap time is longer than the programmed dead-time, the VOA goes high immediately when the VIB goes low.

Condition H: VIB goes high while VIA and VOA are still high, the overlap time is longer than the programmed dead-time. To avoid overshoot, VOA goes low immediately when the VIB goes high. Since the overlap time is longer than the programmed dead-time, the VOB goes high when the VIA goes low.

APPLICATION INFORMATION

The circuit in Figure 13 shows the typical application circuit for SLMi823x to driver a typical half bridge configuration which could be used in several popular power converter topologies such as synchronous buck, synchronous boost, half bridge, full bridge, LLC etc. topologies and 3-phase motor drive applications.

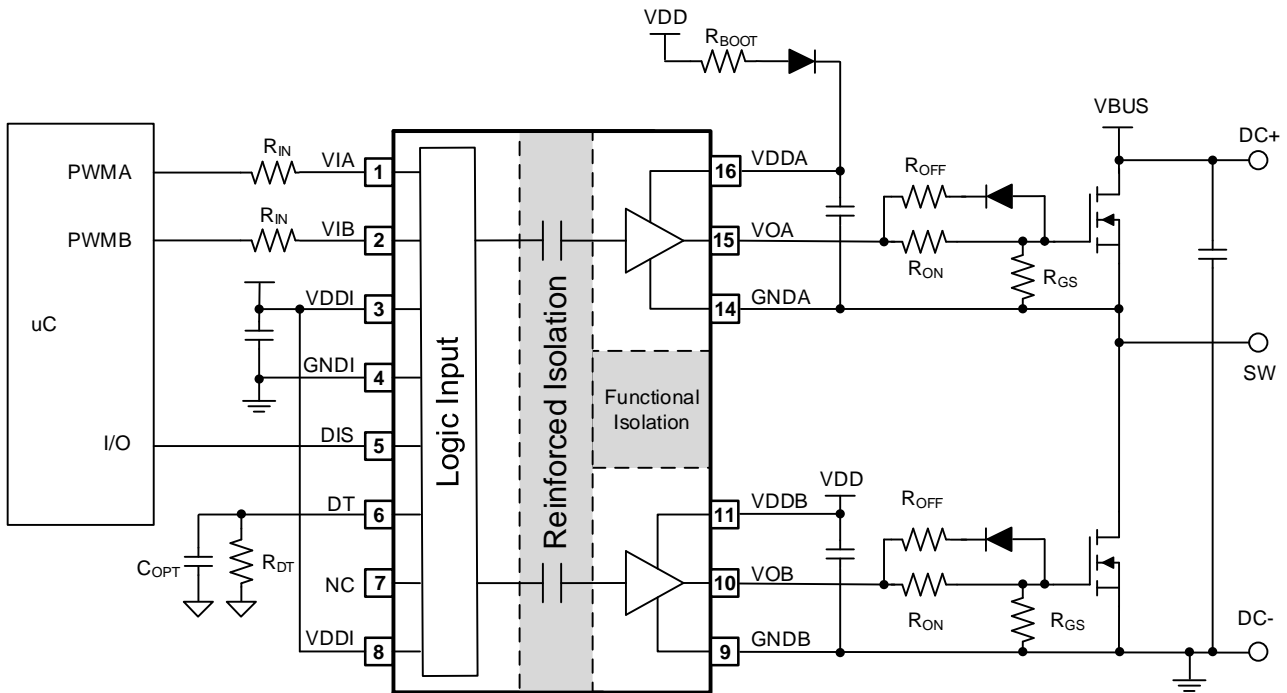

Figure 13. Typical Application Schematic

LAYOUT

Figure 14 and Figure 15 shows a 2 layer PCB layout example with the signals and key components.

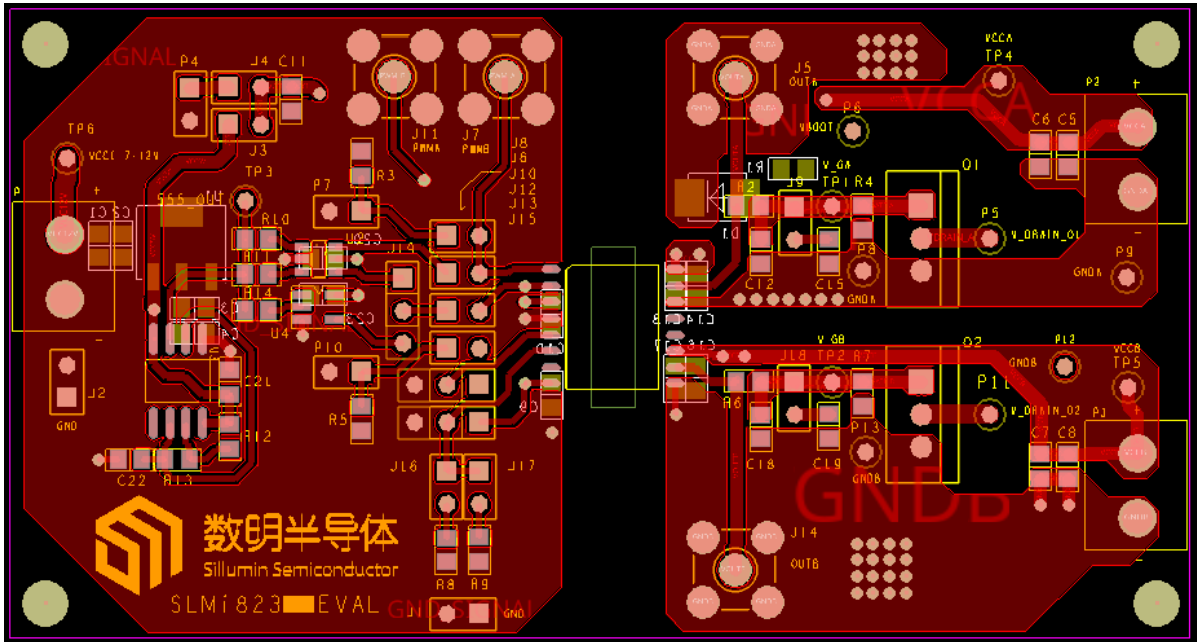

Figure 14. PCB Top View

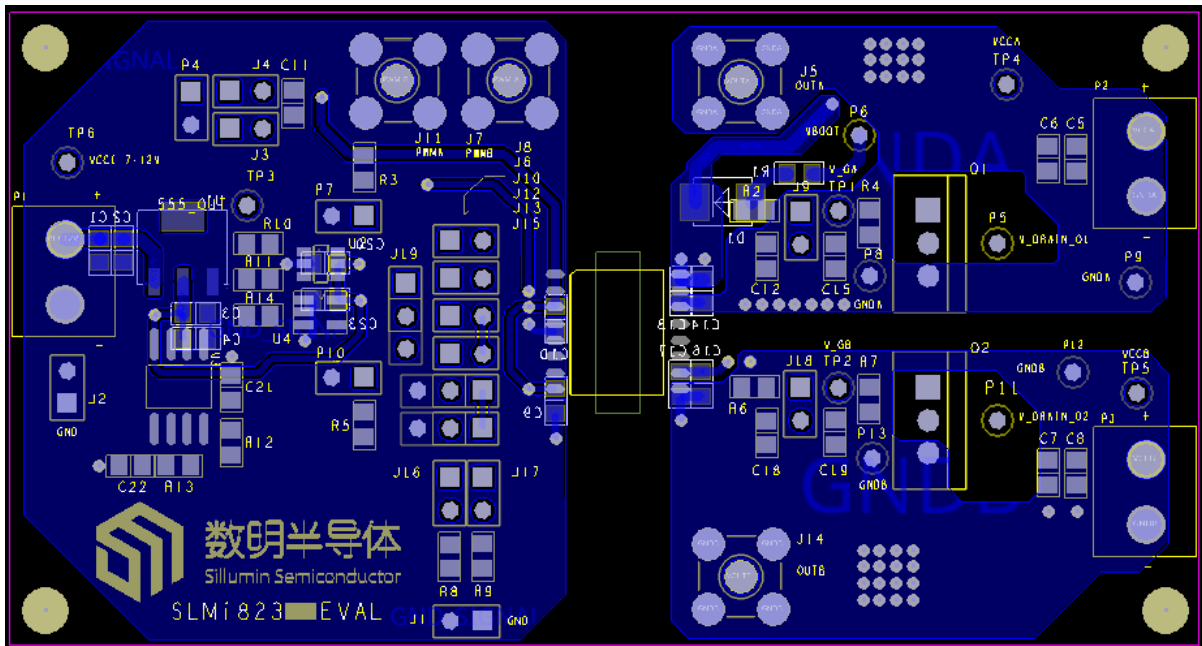

Figure 15. PCB Bottom View

PACKAGE CASE OUTLINES

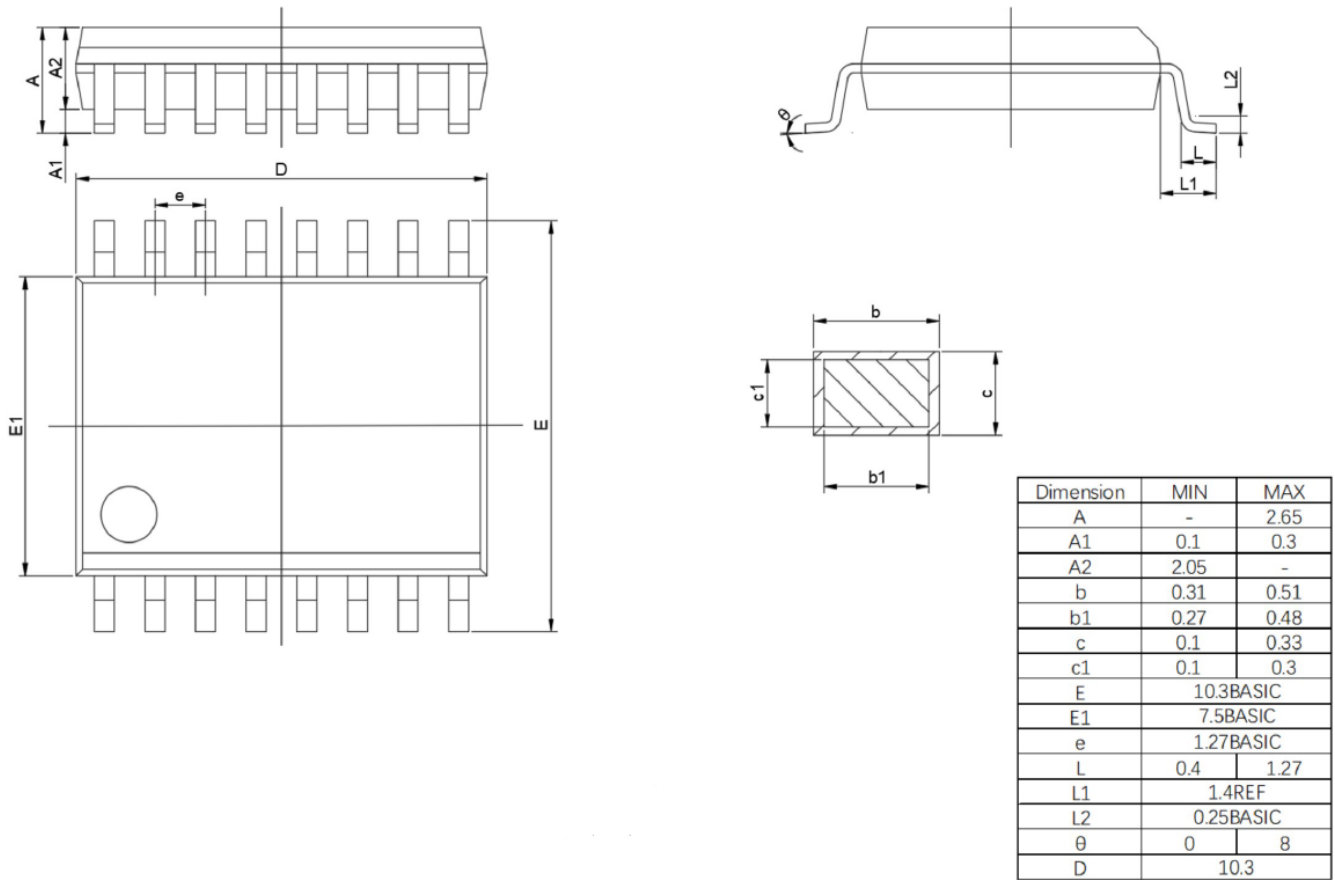
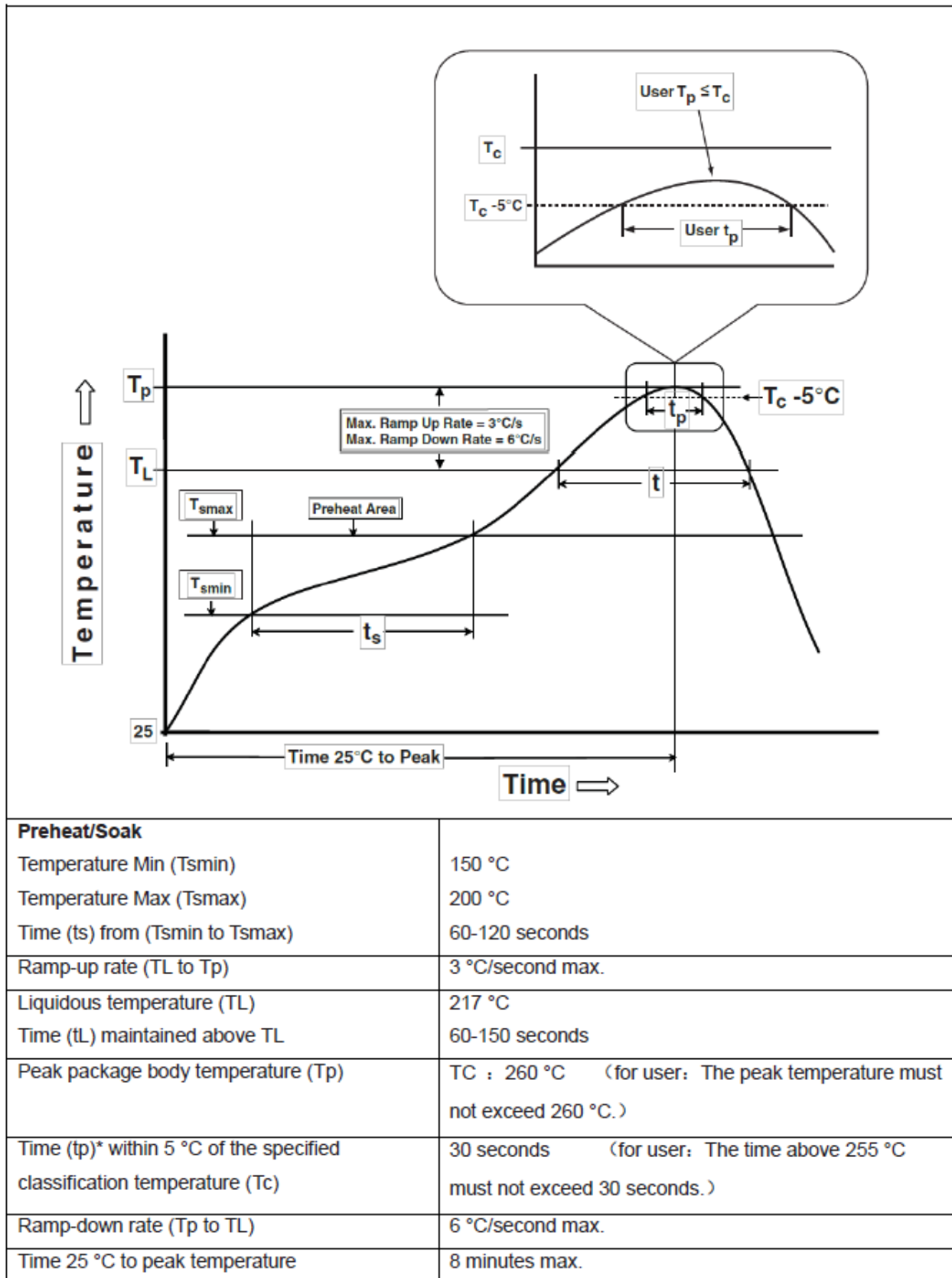

Figure 16. SOP16W Package Outline Dimensions

REFLOW PROFILE GUIDANCE

REVISION HISTORY

Note: page numbers for previous revisions may differ from page numbers in current version

Page or Item	Subjects (major changes since previous revision)
Rev 1.0 datasheet: 2021-12-30	
Whole document	Initial release
Rev 1.1 datasheet: 2022-10-25	
Page 9	Update the values in the absolute maximum ratings table
Page 10	Add thermal information
Page 11	Add the test condition in the Insulation specifications
Page 12	Add safety related certifications Add safety limiting values
Page 13, 14	Updated the I_{VDDI} , R_{PD} , V_{OH} , V_{OL} and add the I_{VDDA} , I_{Vddb} in the electrical characteristics (DC) table
Page 14	Update t_{PWD} , t_{DM} in the switching characteristics (AC) table