

# HPSAV 3000 Pressure Transducer

## General description

Pressure transducer model HPSAV 3000 is an OEM pressure sensing device with temperature compensated and calibrated output.

High performance and accuracy enables use of this transducer in many applications, and with its compact and handy design is very suitable for OEM users. The HPSAV 3000 pressure transducers are constructed on 1 mm thick ceramic substrate with one or two pressure tubes. Thick film resistors printed on substrate are individually laser trimmed to provide temperature compensation, zero and span calibration. Pressure media compatible with this transducers family is dry air or non-corrosive gases and liquids.

The model HPSAV 3000 is designed for constant voltage excitation. Whole family includes pressure ranges from 10 mbar up to 7 bar.

## Features

- Constant voltage excitation
- Easy to use DIP package
- Wide compensated range (0 to 70°C)
- High performance OEM applications
- Zero and span calibration
- Differential, gage and absolute configurations
- Wide pressure range from 10 mbar up to 7 bar

## Applications

- Medical instrumentation
- Respirators
- HVAC
- Process control
- Leak detection
- Pneumatic controls
- Altimeters

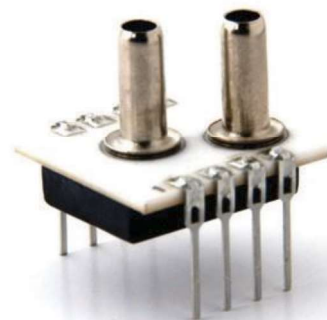

## HPSAV 3000 Pressure Transducer

## Types overview

Pressure range	10 mbar (0,15 psi)	20 mbar (0,3 psi)	50 mbar (0,8 psi)	100 mbar (1,5 psi)
ID group	HPSAV 3000-010M	HPSAV 3000-020M	HPSAV 3000-050M	HPSAV 3000-100M
$V_{OUT}^{3)}$	25±0,5 mV	25±0,5 mV	25±0,5 mV	25±0,5 mV
$V_{OFS(MAX)}$	±0,3mV	±0,3 mV	±0,3 mV	±0,3 mV
Temp. ranges	Operating: -25 to 85°C Compensated: 0 to 70°C Storage: -40 to 125°C			
Over pressure <sup>1)</sup>	100 mbar	200 mbar	500 mbar	1000 mbar
Burst pressure <sup>2)</sup>	150 mbar	300 mbar	750 mbar	1500 mbar

Pressure range	350 mbar (5 psi)	1 bar (15 psi)	2 bar (30 psi)	4 bar (60 psi)	7 bar (100 psi)
ID	HPSAV 3000-350M	HPSAV 3000-001B	HPSAV 3000-002B	HPSAV 3000-004B	HPSAV 3000-007B
$V_{OUT}^{3)}$	80±1 mV	80±1 mV	80±1 mV	80±1 mV	80±1 mV
$V_{OFS(MAX)}$	±0,3mV	±0,3 mV	±0,3 mV	±0,3 mV	±0,3mV
Temp. ranges	Operating: -25 to 85°C Compensated: 0 to 70°C Storage: -40 to 125°C				
Over pressure <sup>1)</sup>	1 bar	3 bar	6 bar	8 bar	14 bar
Burst pressure <sup>2)</sup>	1,7 bar	5 bar	10 bar	12 bar	21 bar

$$T_{AMB} = 25^{\circ}C$$

$$V_{CC} = 10 V, \text{ unless otherwise noted}$$

## HPSAV 3000 Pressure Transducer

## Performance characteristics

Parameter	Min.	Typ.	Max.	Unit
Input voltage		10	20	V
Thermal error of span (0 to 70°C) <sup>5), 6)</sup>		±0,2	±1	%FS
Thermal error of offset (0 to 70°C) <sup>4), 6)</sup>		±0,2	±0,5	mV
Combined linearity and hysteresis <sup>8)</sup>		±0,2	±0,5	%FS
Input impedance	4		25	kΩ
Output impedance	2		4	kΩ
Repeatability <sup>7)</sup>		±0,05		%FSO
Long term stability of offset and span		±0,1		mV
Media compatibility	See spec. note <sup>9), 10)</sup>			
Weight		2		g

## Specification notes

- 1) Over pressure is the maximum pressure which may be applied without causing damage to the sensing element.
- 2) Burst pressure is the maximum pressure which may be applied without causing leakage damage to the sensing element.
- 3) Analog output signal is ratiometric to input supply voltage  $V_{cc}$ .
- 4) Offset voltage is the voltage output at zero pressure.
- 5) Span is the algebraic difference between the output at full scale pressure range and offset.
- 6) Thermal error of span and offset represents the maximum deviation of transducer signal (span and offset) through whole compensated temperature range from 0 to 70°C in compare to value at 25°C. For pressure ranges  $p \leq 100$  mbar this parameter is defined as 0.5 mV max.
- 7) Repeatability is defined as typical deviation of the output signal after 10 pressure cycles.
- 8) Nonlinearity is defined as the BFS (best fit straight line) across entire pressure range.
- 9) Media compatibility: on pressure port P1: clean, dry and noncorrosive gases to silicon, Pyrex, RTV, gold, ceramics  $Al_2O_3$ , epoxy, tin.
- 10) Media compatibility: on pressure port P2: noncorrosive gases or liquids to silicon, Pyrex, RTV, ceramics  $Al_2O_3$ , epoxy, tin.

# HPSAV 3000 Pressure Transducer

## Outline dimensions and pinout

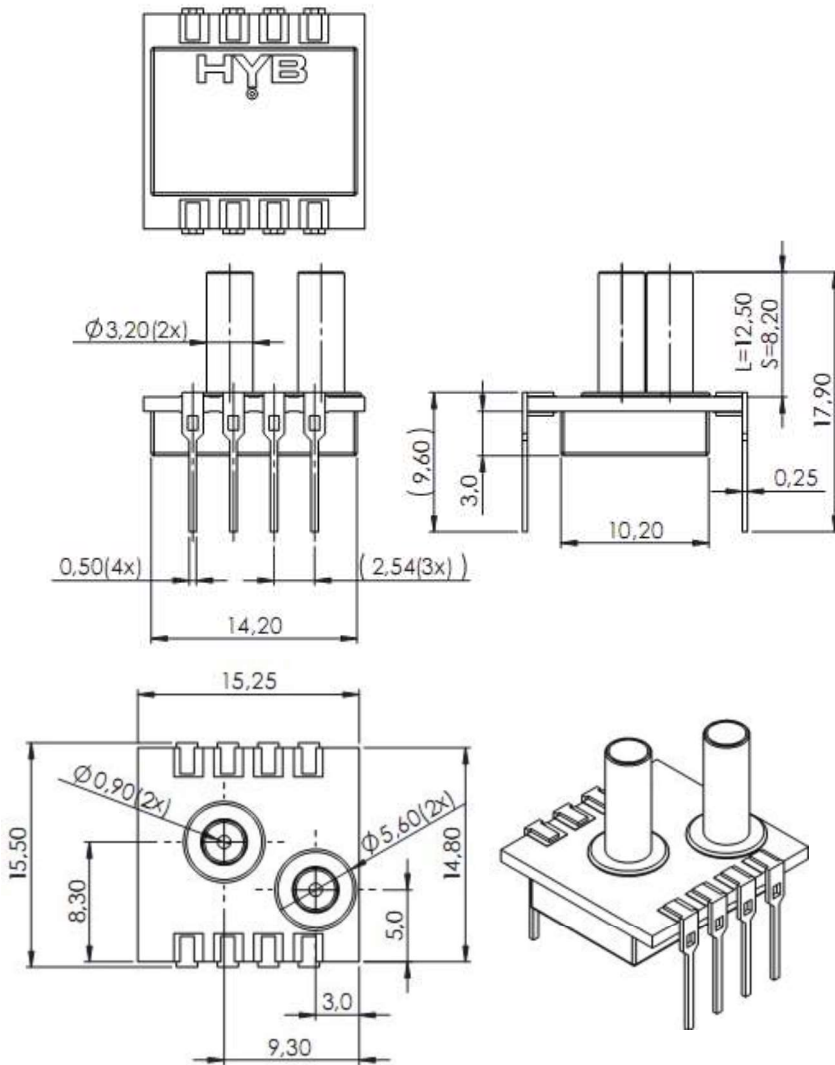

Note: Output polarity is for absolute type reverse.

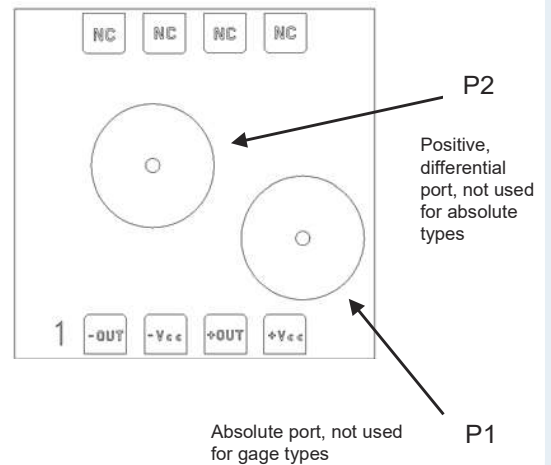

## HPSAV 3000 Pressure Transducer

## Ordering guide

Transducer type	Pressure range	Pressure type	Pressure port
HPSAV 3000	010M	D	L
	020M	G	S
	050M	A	0
	100M		
	350M		
	001B		
	002B		
	004B		
	007B		

Pressure range	
010M	10 mbar
020M	20 mbar
050M	50 mbar
100M	100 mbar
350M	350 mbar
001B	1 bar
002B	2 bar
004B	4 bar

Pressure type	
D	Differential
G	Gage
A	Absolute (for $p \geq 1$ bar)

Pressure port	
L	Long
S	Short

Other configurations possible on special request.