

■ Features

- $V_{DS} (V) = -30V$
- $I_D = -5.1A (V_{GS} = -10V)$
- $R_{DS(ON)} < 45m\Omega (V_{GS} = -10V)$
- $R_{DS(ON)} < 68m\Omega (V_{GS} = -4.5V)$

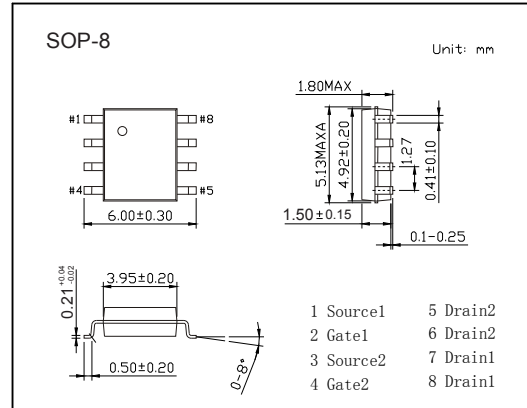
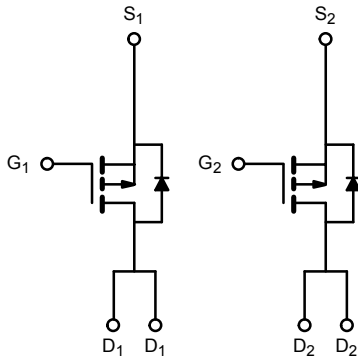

■ Absolute Maximum Ratings $T_a = 25^\circ C$

Parameter	Symbol	Rating	Unit
Drain-Source Voltage	V_{DS}	-30	V
Gate-Source Voltage	V_{GS}	± 20	
Continuous Drain Current	I_D	$T_a = 25^\circ C$	-5.1
		$T_a = 70^\circ C$	-4.2
Pulsed Drain Current	I_{DM}	-30	A
Power Dissipation	P_D	$T_a = 25^\circ C$	2
		$T_a = 70^\circ C$	1.3
Thermal Resistance Junction- to-Ambient	R_{thJA}	62.5	$^\circ C/W$
Junction Temperature	T_J	150	$^\circ C$
Junction Storage Temperature Range	T_{stg}	-55 to 150	

■ Electrical Characteristics Ta = 25°C

Parameter	Symbol	Test Conditions	Min	Typ	Max	Unit
Drain-Source Breakdown Voltage	V _{DSS}	I _D =-250 μ A, V _{GS} =0V	-30			V
Zero Gate Voltage Drain Current	I _{DSS}	V _{DS} =-30V, V _{GS} =0V			-1	μA
		V _{DS} =-30V, V _{GS} =0V, T _J =55°C			-25	
Gate-Body leakage current	I _{GSS}	V _{DS} =0V, V _{GS} =±20V			±100	nA
Gate Threshold Voltage	V _{GS(th)}	V _{DS} =V _{GS} I _D =-250 μ A	-1		-3	V
Static Drain-Source On-Resistance	R _{DS(on)}	V _{GS} =-10V, I _D =-5A		45		mΩ
		V _{GS} =-4.5V, I _D =-5A		68		
On state drain current	I _{D(ON)}	V _{GS} ≤-5V, V _{DS} =-10V	-20			A
Forward Transconductance	g _{FS}	V _{DS} =-15V, I _D =-5A		10		S
Gate resistance	R _g		2		7.1	Ω
Total Gate Charge	Q _g	V _{GS} =-10V, V _{DS} =-15V, I _D =-5A		16	25	nC
Gate Source Charge	Q _{gs}			5		
Gate Drain Charge	Q _{gd}			2		
Turn-On DelayTime	t _{d(on)}	V _{GS} =-10V, V _{DS} =-15V, R _L =15Ω, R _G =6Ω		9	15	ns
Turn-On Rise Time	t _r			13	20	
Turn-Off DelayTime	t _{d(off)}			25	40	
Turn-Off Fall Time	t _f			15	25	
Body Diode Reverse Recovery Time	t _{rr}	I _F =-1.7A, di/dt=100A/μ s		60	90	
Diode Forward Voltage	V _{SD}	I _S =-1.7A, V _{GS} =0V (Note.1)			-1.2	V

Note.1:Pulse test; pulse width ≤ 300 us, duty cycle ≤ 2%.

Typical Characteristics

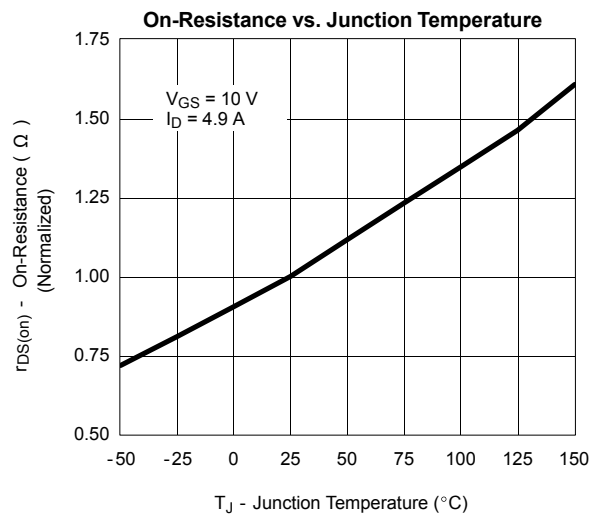
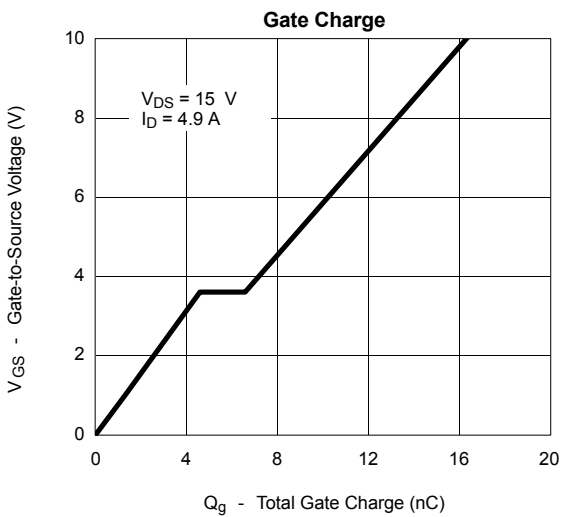
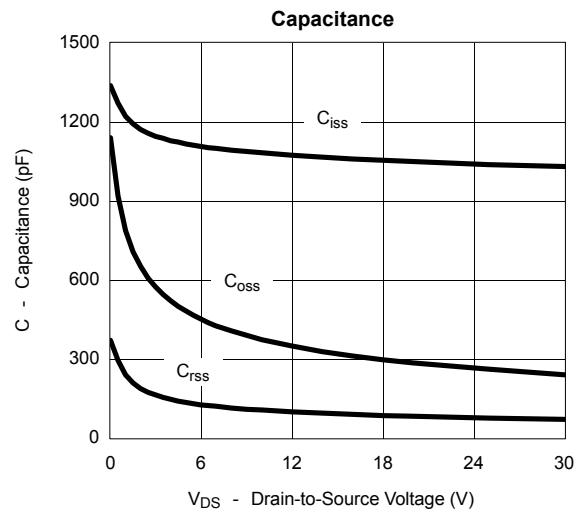
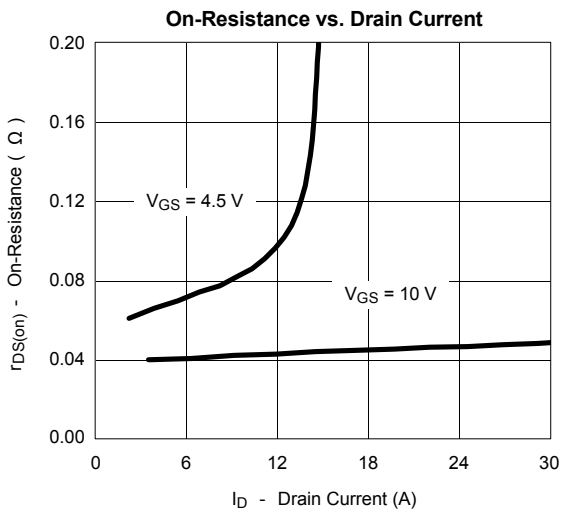
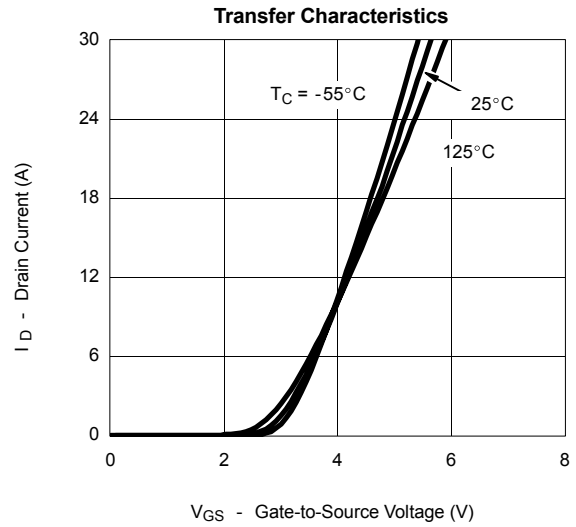
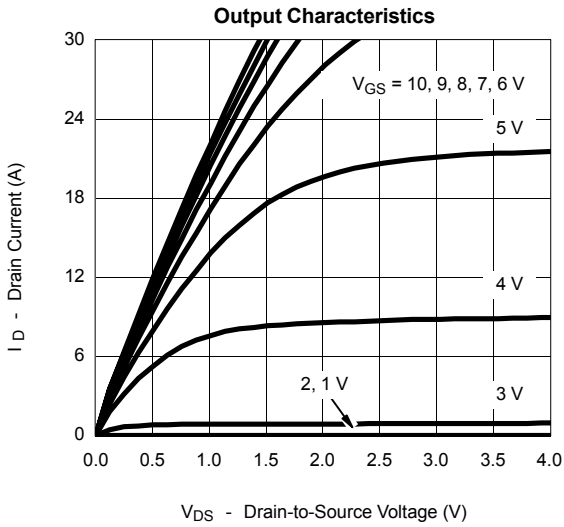

Typical Characteristics

