

N-Channel 50-V(D-S) MOSFET

V(BR)DSS	RDS(on)MAX	ID
50 V	2Ω@10V	300mA
	3Ω@4.5V	

FEATURE:

- Rugged and Reliable
- High density cell design for extremely low RDS(on)
- ESD Protected

APPLICATION:

- ※ Direct Logic-Level Interface: TTL/CMOS
- ※ Drivers: Relays, Solenoids, Lamps, Hammers, Display, Memories, Transistors, etc.
- ※ Battery Operated Systems
- ※ Solid-State Relays

MARKING:

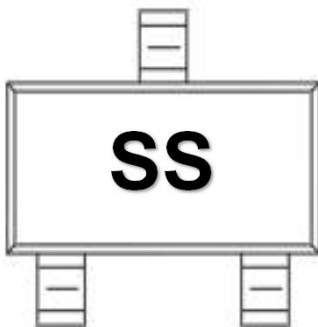

Equivalent Circuit:

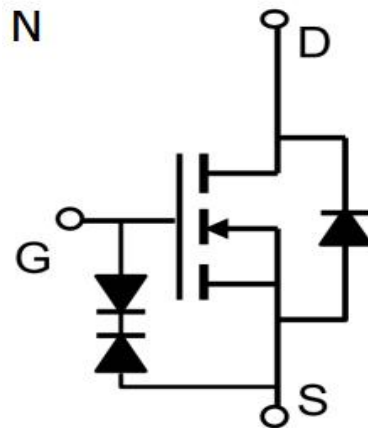

SOT-23

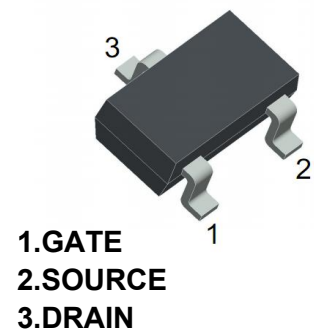

Mosfet Maximum ratings (Ta=25°C unless otherwise noted)

Parameter	Symbol	Value	Unit
Drain-Source Voltage	VDS	50	V
Gate-Source Voltage	VGS	±20	
Continuous Drain Current	ID	0.3	A
Continuous Source-Drain Current(Diode Conduction)	IS	1.3	
Power Dissipation	PD	0.35	W
Thermal Resistance from Junction to Ambient	RθJA	357	°C/W
Junction Temperature	TJ	150	°C
Storage Temperature	TSTG	-55~+150	°C

MOSFET ELECTRICAL CHARACTERISTICS
unless otherwise specified Ta = 25 °C

Parameter	Symbol	Test Condition	Min	Typ	Max	Unit
Characteristics						
Drain-source breakdown voltage	V(BR)DSS	VGS = 0V , ID =250μA	50			V
Gate-threshold voltage	VGS(th)	VDS =VGS , ID =250μA	0.8		1.6	V
Gate-body leakage	IGSS	VDS =0V , VGS =±20V			±1	μA
Zero gate voltage drain current	IDSS	VDS =30V , VGS =0V			1	μA
Drain-source on-resistancea	RDS(on)	VGS =10V , ID = 300mA		1.1	2	Ω
		VGS =4.5V , ID =300mA		1.2	3	Ω
Forward transconductancea	gfs	VDS =10V , ID =300mA	0.12			S
Diode forward voltage	VSD	IS=100mA , VGS=0V		0.8	1.28	V
Dynamic Characteristics						
Input capacitance	Ciss	VDS =25V ,VGS =0V, f=1MHz		27		pF
Output capacitance	Coss			13		pF
Reverse transfer capacitanceb	Crss			6		pF
Switchingb Characteristics						
Turn-on delay time	td(on)	VDD=30V Rg=2Ω, ID =220mA, VGEN=4.5V,RL=3Ω			5	ns
Rise time	tr				18	ns
Turn-off delay time	td(off)				36	ns
Fall time	tf				14	ns

Note :

1. These parameters have no way to verify.
2. Pulse Test ; Pulse Width ≤300μs, Duty Cycle ≤2%.

SOT-23 PACKAGE OUTLINE DIMENSIONS

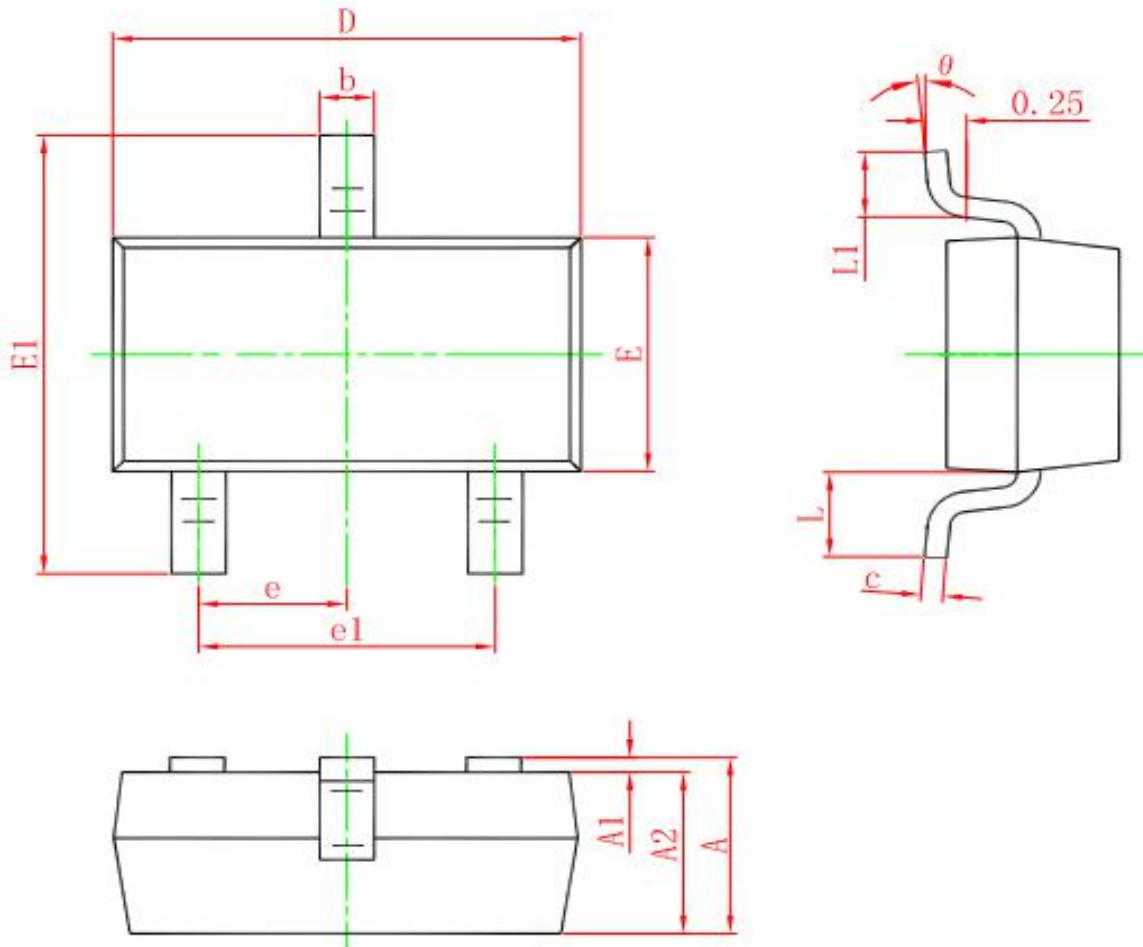

Symbol	Dimensions In Millimeters		Dimensions In Inches	
	Min.	Max.	Min.	Max.
A	0.900	1.150	0.035	0.045
A1	0.000	0.100	0.000	0.004
A2	0.900	1.050	0.035	0.041
b	0.300	0.500	0.012	0.020
c	0.080	0.150	0.003	0.006
D	2.800	3.000	0.110	0.118
E	1.200	1.400	0.047	0.055
E1	2.250	2.550	0.089	0.100
e	0.950 TYP.		0.037 TYP.	
e1	1.800	2.000	0.071	0.079
L	0.550 REF.		0.022 REF.	
L1	0.300	0.500	0.012	0.020
θ	0°	8°	0°	8°