



## Description

### JMT N-channel MOSFET

#### Features

- $V_{DS}=30V$ ,  $I_D=13A$
- $R_{DS(ON)}=9m\Omega$  (Typ.) @  $V_{GS}=10V$   
 $R_{DS(ON)}=11m\Omega$  (Typ.) @  $V_{GS}=4.5V$
- Low Gate Charge
- Low Reverse Recovery Charge
- Fast Switching
- Improved  $dv/dt$  Capability

#### Application

- Uninterruptible Power Supply(UPS)
- DC-DC Power Converter
- Synchronous Rectification

#### Package



SOP-8

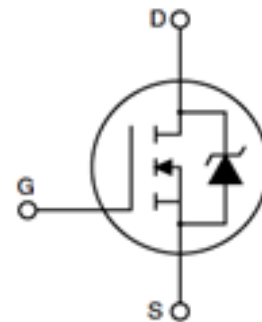
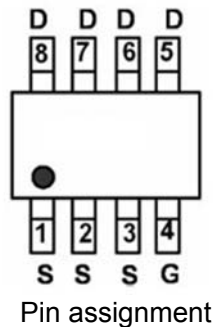

### Absolute Maximum Ratings (T<sub>C</sub>=25°C unless otherwise specified)

Symbol	Parameter	Max.	Units
$V_{DSS}$	Drain-Source Voltage	30	V
$V_{GSS}$	Gate-Source Voltage	±20	V
$I_D$	Continuous Drain Current	T <sub>C</sub> = 25°C	13
		T <sub>C</sub> = 100°C	8
$I_{DM}$	Pulsed Drain Current <sup>note1</sup>	52	A
$P_D$	Power Dissipation	T <sub>A</sub> = 25°C	3.1
$R_{\theta JA}$	Thermal Resistance, Junction to Ambient	40	°C/W
T <sub>J</sub> , T <sub>STG</sub>	Operating and Storage Temperature Range	-55 to +150	°C



## Electrical Characteristics (T<sub>C</sub>=25°C unless otherwise specified)

Symbol	Parameter	Test Condition	Min.	Typ.	Max.	Units
<b>Off Characteristic</b>						
V <sub>(BR)DSS</sub>	Drain-Source Breakdown Voltage	V <sub>GS</sub> =0V, I <sub>D</sub> =250μA	30	-	-	V
I <sub>DSS</sub>	Zero Gate Voltage Drain Current	V <sub>DS</sub> =30V, V <sub>GS</sub> =0V,	-	-	1.0	μA
I <sub>GSS</sub>	Gate to Body Leakage Current	V <sub>DS</sub> =0V, V <sub>GS</sub> =±20V	-	-	±100	nA
<b>On Characteristics</b>						
V <sub>GS(th)</sub>	Gate Threshold Voltage	V <sub>DS</sub> = V <sub>GS</sub> , I <sub>D</sub> = 250μA	0.8	-	2.2	V
R <sub>DSON</sub>	Static Drain-Source on-Resistance <small>note2</small>	V <sub>GS</sub> =10V, I <sub>D</sub> =13A	-	9	12	mΩ
		V <sub>GS</sub> =4.5V, I <sub>D</sub> =10A	-	11	15	
g <sub>FS</sub>	Forward Transconductance	V <sub>DS</sub> =5V, I <sub>D</sub> =13A	-	43	-	S
<b>Dynamic Characteristics</b>						
C <sub>iss</sub>	Input Capacitance	V <sub>DS</sub> =15V, V <sub>GS</sub> = 0V, f = 1.0MHz	-	1250	-	pF
C <sub>oss</sub>	Output Capacitance		-	168	-	pF
C <sub>rss</sub>	Reverse Transfer Capacitance		-	127	-	pF
Q <sub>g</sub>	Total Gate Charge	V <sub>DS</sub> =30V, I <sub>D</sub> =13A, V <sub>GS</sub> =10V	-	23	-	nC
Q <sub>gs</sub>	Gate-Source Charge		-	2.2	-	nC
Q <sub>gd</sub>	Gate-Drain("Miller") Charge		-	5.5	-	nC
<b>Switching Characteristics</b>						
t <sub>d(on)</sub>	Turn-on Delay Time	V <sub>DS</sub> =15V, I <sub>D</sub> =1A, R <sub>G</sub> =3Ω, V <sub>GS</sub> =4.5V	-	15	-	ns
t <sub>r</sub>	Turn-on Rise Time		-	25	-	ns
t <sub>d(off)</sub>	Turn-off Delay Time		-	39	-	ns
t <sub>f</sub>	Turn-off Fall Time		-	22	-	ns
<b>Drain-Source Diode Characteristics and Maximum Ratings</b>						
I <sub>S</sub>	Maximum Continuous Drain to Source Diode Forward Current		-	-	13	A
I <sub>SM</sub>	Maximum Pulsed Drain to Source Diode Forward Current		-	-	52	A
V <sub>SD</sub>	Drain to Source Diode Forward Voltage	V <sub>GS</sub> =0V, I <sub>S</sub> =30A	-	0.8	1.3	V
t <sub>rr</sub>	Reverse Recovery Time	I <sub>S</sub> =13A,	-	13	-	ns
Q <sub>rr</sub>	Reverse Recovery Charge	di/dt=100A/μs	-	1.6	-	nC

Notes:1. Repetitive Rating: Pulse Width Limited by Maximum Junction Temperature

2. Pulse Test: Pulse Width≤300μs, Duty Cycle≤2%

## Typical Performance Characteristics

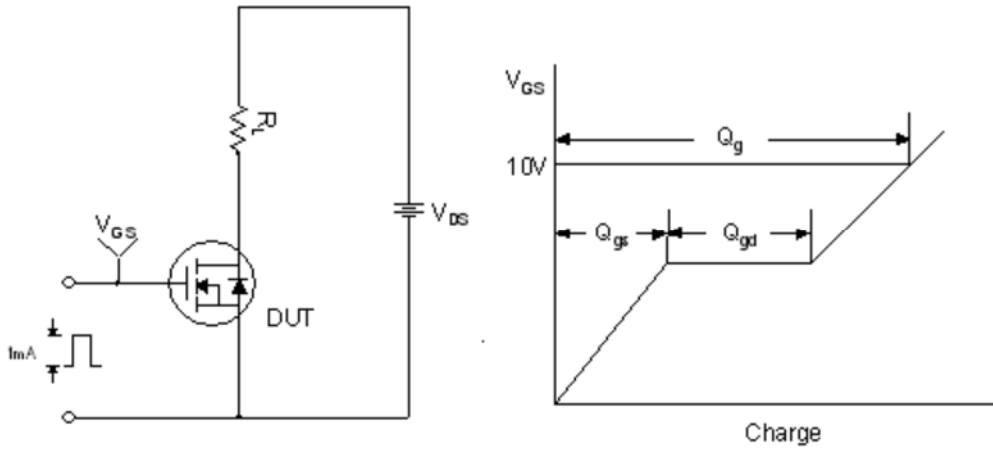

Figure 1. Gate Charge Test Circuit & Waveform

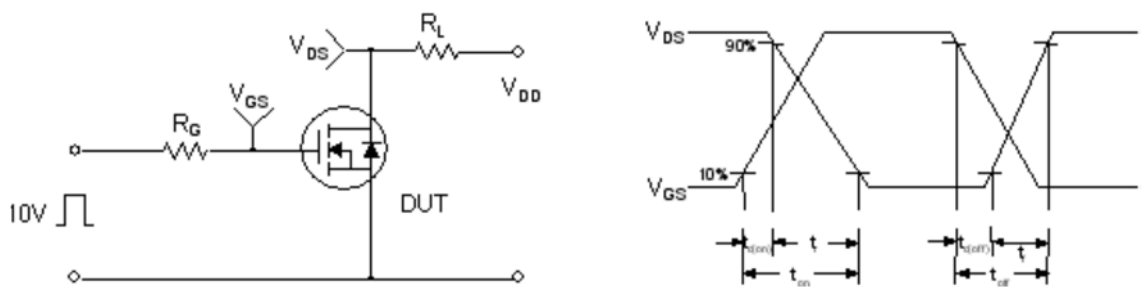

Figure 2. Resistive Switching Test Circuit & Waveforms

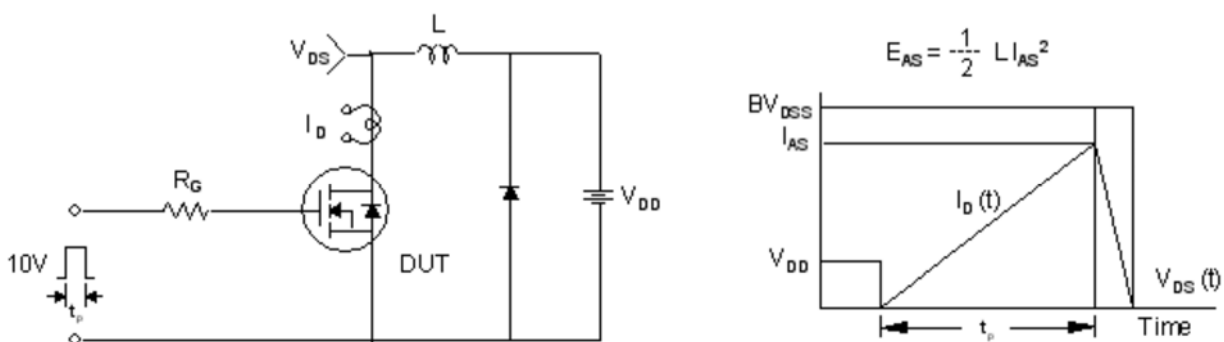

Figure 3. Unclamped Inductive Switching Test Circuit & Waveforms

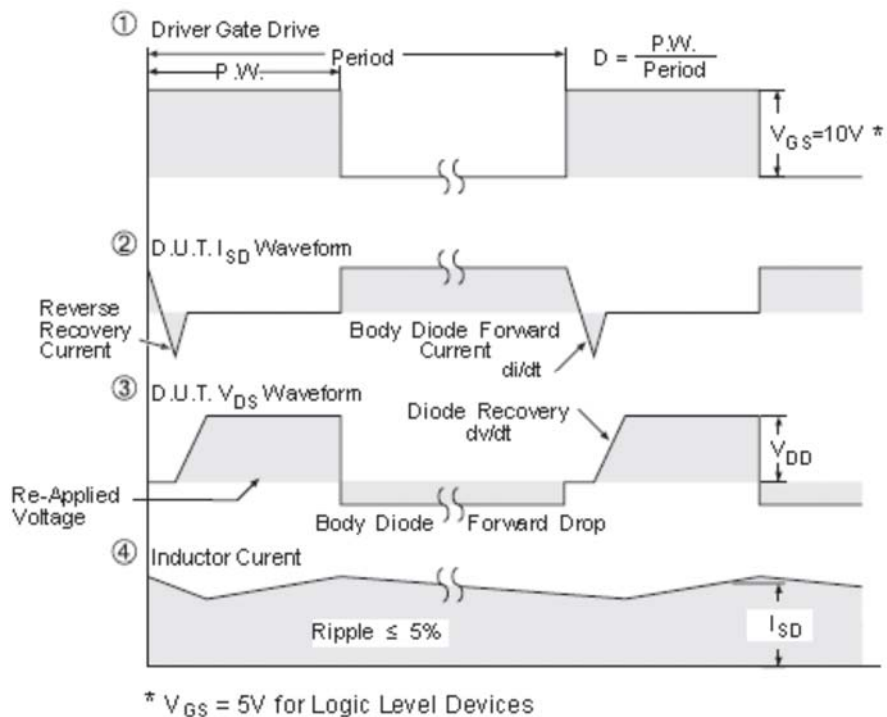
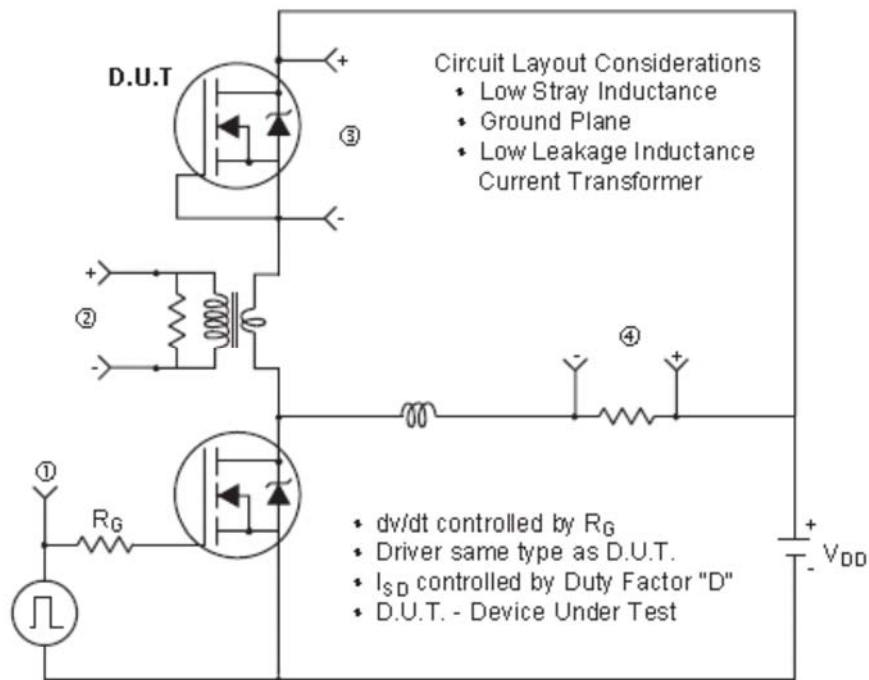
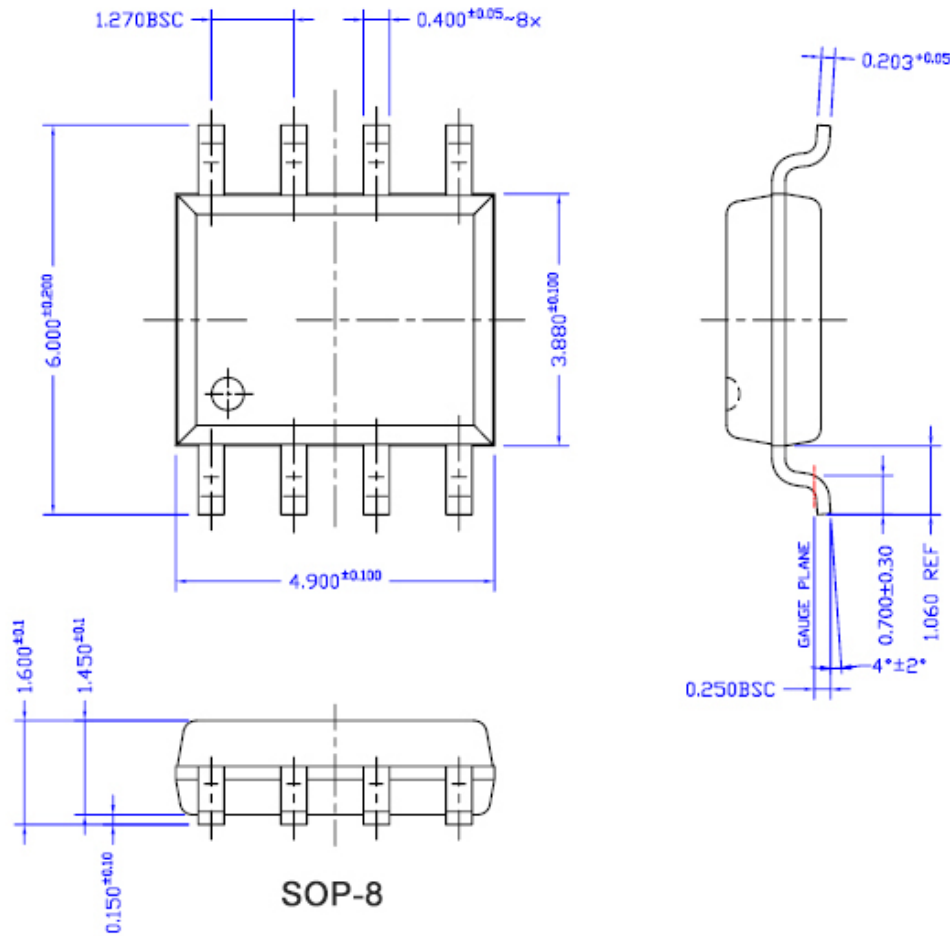

Figure 4. Peak Diode Recovery  $dv/dt$  Test Circuit & Waveforms (For N-channel)



## Package Mechanical Data



Information furnished in this document is believed to be accurate and reliable. However, Jiangsu JieJie Microelectronics Co.,Ltd assumes no responsibility for the consequences of use without consideration for such information nor use beyond it.

Information mentioned in this document is subject to change without notice, apart from that when an agreement is signed, Jiangsu JieJie complies with the agreement.

Products and information provided in this document have no infringement of patents. Jiangsu JieJie assumes no responsibility for any infringement of other rights of third parties which may result from the use of such products and information.

This document is the first version which is made in 7-Nov.-2018. This document supersedes and replaces all information previously supplied.

 is a registered trademark of Jiangsu JieJie Microelectronics Co.,Ltd.  
Copyright ©2018 Jiangsu JieJie Microelectronics Co.,Ltd. Printed All rights reserved.